

# C24 Dynamical Systems

---

8 Lectures Michaelmas Term 2025

Mark Cannon

mark.cannon@eng.ox.ac.uk

With thanks to Charles Monroe and Antonis Papachristodoulou for permission to use their notes from previous years

---

## Contents

<b>1</b>	<b>Introduction to Dynamical Systems</b>	<b>1</b>
1.1	Examples of Dynamical Systems . . . . .	3
1.2	Terminology, Notation and Relevant Background . . . . .	11
1.2.1	Eigenvalues and Eigenvectors . . . . .	11
1.2.2	Linear Autonomous Systems . . . . .	12
1.2.3	The matrix exponential . . . . .	13
1.3	Different types of Dynamical Systems . . . . .	14
<b>2</b>	<b>Equilibria and Stability</b>	<b>18</b>
2.1	Equilibrium Solutions . . . . .	18
2.2	Stability . . . . .	19
2.3	Linear Systems . . . . .	20
2.3.1	Second order systems . . . . .	21
2.4	Nonlinear Systems . . . . .	28
<b>3</b>	<b>Invariant manifolds</b>	<b>31</b>
3.1	Linear Systems: Stable, Unstable and Centre Subspaces . . . . .	31
3.2	Nonlinear Systems: Local theory and Invariance . . . . .	36
3.3	Non-hyperbolic equilibria . . . . .	37
<b>4</b>	<b>Lyapunov functions</b>	<b>41</b>
4.1	Lyapunov Functions . . . . .	42

4.2	Vector fields possessing an integral . . . . .	46
4.3	Hamiltonian Systems . . . . .	47
4.4	Gradient Systems . . . . .	48
4.5	A relationship between Gradient and Hamiltonian Systems . .	48
<b>5</b>	<b>Asymptotic Behaviour</b>	<b>50</b>
5.1	LaSalle's invariance principle . . . . .	53
5.2	The Poincaré Bendixson Theorem . . . . .	55
<b>6</b>	<b>Limit Cycles and Index Theory</b>	<b>61</b>
6.1	Non-existence of Periodic Orbits for 2-D systems . . . . .	61
6.2	Gradient Systems . . . . .	63
6.3	Index Theory . . . . .	63
6.4	Limit cycles . . . . .	68
6.5	The Poincaré Map . . . . .	69
<b>7</b>	<b>Bifurcations</b>	<b>72</b>
7.1	One-dimensional Bifurcations . . . . .	72
7.2	Hopf Bifurcations . . . . .	77
<b>8</b>	<b>Chaos</b>	<b>83</b>
8.1	Chaos in Maps . . . . .	83
8.2	Chaos in Flows . . . . .	88
8.3	Back to maps: Mandelbrot set . . . . .	90

# 1 Introduction to Dynamical Systems

Dynamical Systems is a discipline which studies the properties of sets of differential equations (in continuous or discrete time) without solving them. These differential equations usually model the behaviour of a physical system. For example, one can use dynamical systems theory to study mechanical systems (e.g. the equations of motion of a simple pendulum) or the dynamics of an ecosystem. Other application areas include the study of planetary orbits, fluid mechanics, biology and many others.

The origins of Dynamical Systems can be traced back to Newtonian Mechanics, where the solution of a set of differential equation models was used to describe the time evolution of a mechanical system. The properties of many systems, however, are difficult to understand by just looking at *trajectories*. For example, it is difficult to appreciate the role of changes in parameters and other uncertainties and classifying the type of trajectories (e.g. whether they lead to a stable equilibrium, tend to a limit cycle, etc.). The need for a field that studies such properties was identified by Henri Poincaré, who developed much of the theory of Dynamical Systems, applied to planetary motions. Several other researchers, such as Arnol'd, Pontryagin, Smale, etc. developed the field further.

In this 8-lecture course, we will study several aspects of Dynamical Systems theory and how it is applied in a range of examples. The syllabus is as follows:

Introduction to Dynamical Systems. Examples from different fields. Maps, flows and questions of interest. Existence and uniqueness of solutions. A geometric way of thinking about differential equations. Phase space, equilibria. Stability and linearized stability. Saddles, nodes, foci and centres. Hartman-Grobman theorem. Lyapunov functions. Gradient and Hamiltonian Systems. Vector fields possessing an integral. Invariance. La Salle's theorem. Domain of attraction. Limit sets, attractors, periodic orbits, limit cycles. Poincaré maps. Poincaré-Bendixson theorem. Index theory. Saddle-

node, transcritical, pitchfork and Hopf bifurcations. Logistic map. Fractals. Chaos. Lorenz equations.

This will be covered as follows:

1. Lecture 1: Introduction to Dynamical Systems. Examples from different fields. Maps, flows and questions of interest. Existence and uniqueness of solutions. A geometric way of thinking about differential equations.
2. Lecture 2: Phase space, equilibria. Stability and linearized stability. Saddles, nodes, foci and centres.
3. Lecture 3: The stable, unstable and centre subspaces. Hartman-Grobman theorem.
4. Lecture 4: Lyapunov functions. Gradient and Hamiltonian Systems. Vector fields possessing an integral.
5. Lecture 5: Invariance. La Salle's theorem. Domain of attraction.
6. Lecture 6: Limit sets, attractors, periodic orbits, limit cycles. Poincaré maps. Poincaré-Bendixson theorem. Index theory.
7. Lecture 7: Saddle-node, transcritical, pitchfork and Hopf bifurcations.
8. Lecture 8: Logistic map. Fractals. Chaos. Lorenz equations.

These notes contain most of the material you will need for this course; however, especially when attempting the examples sheets, you may need to refer to textbooks. The following books are recommended:

1. "Nonlinear Dynamics and Chaos: With Applications to Physics, Biology, Chemistry and Engineering" by Steven H. Strogatz. CRC Press, 2015 (2nd edition), 2024 (3rd edition). This is a very easy-to-read and understand textbook on dynamical systems.
2. "Differential Equations and Dynamical Systems" by Lawrence Perko. Springer, 2013 (3rd edition). This is a more mathematical textbook which covers some of the material in these notes in more detail.
3. "Nonlinear Systems", by Hassan K. Khalil. Pearson Education, 2013 (3rd

edition). Provides a thorough mathematical analysis of the topics covered in this lecture course.

Lectures will be pre-recorded and made available on Canvas.

These lecture notes and other information will be available on the C24 pages on Canvas and at: <https://markcannon.github.io/teaching>

For questions, comments, and to report bugs and typos please email: [mark.cannon@eng.ox.ac.uk](mailto:mark.cannon@eng.ox.ac.uk)

There will be two examples classes: one covering lectures 1-4 and one covering lectures 5-8. The classes will be held in Hilary Term 2026.

There will be a revision class in Trinity Term.

## 1.1 Examples of Dynamical Systems

Let's begin with a few examples.

### Single species growth

Consider the case of a single species striving for its own food: this species can grow and reach a population size, which we assume will be limited by resource availability. If the population size happens to be above this so-called *carrying capacity* limit, it will have to decrease. A simple model of this behaviour is the *logistic equation*, which takes the form:

$$\dot{x} = bx \left(1 - \frac{x}{K}\right) \quad (1.1)$$

where  $x$  is the population at time  $t$ ,  $\dot{x} = dx/dt$ ,  $b > 0$  is the growth (birth) rate, and  $K$  is the carrying capacity.

Let's try to solve this differential equation. We have

$$\frac{dx}{bx \left(1 - \frac{x}{K}\right)} = dt$$

The left hand side can be split using partial fractions to give

$$\frac{dx}{bx} + \frac{dx}{bK \left(1 - \frac{x}{K}\right)} = dt$$

and integrated, resulting in

$$\ln |x| - \ln \left| 1 - \frac{x}{K} \right| = bt + \ln c$$

where  $c$  is a constant of integration. After a bit of maths, and assuming that  $x > 0$  we obtain the solution

$$x(t) = \frac{cKe^{bt}}{K + ce^{bt}}$$

Where do solutions tend to as  $t \rightarrow \infty$ ? One can take the limit as  $t \rightarrow \infty$  and conclude that  $\lim_{t \rightarrow \infty} x(t) = K$ .

Quite a bit of maths for a first order differential equation, modelling the growth of *one* species! Imagine what this would look like if there were several species involved.

Also, is this the complete story? What happens if  $x(0) = 0$ , e.g. at the ‘beginning of time’? Or if for some reason we were interested in negative  $x(0)$ ? In these cases one would have to be more careful and explore all possibilities.

Dynamical systems differs from differential equation theory - in Dynamical Systems, we are not concerned with obtaining solutions to the differential equations modelling a system, but rather argue about the solution properties.

Let’s consider the right hand side of (1.1). Figure 1 shows what is called the *phase line* of this system, the  $x$  axis. Circles indicate where  $\dot{x} = 0$ , corresponding to points from which if someone ‘started’ (s)he would ‘stay there forever’.

$$bx \left( 1 - \frac{x}{K} \right) = 0 \Leftrightarrow x = 0 \text{ or } x = K$$

These are called *equilibria*. One can evaluate the direction of the *velocity*,  $\frac{dx}{dt}$ , on either side of the equilibria and indicate whether the evolution of (1.1) would be such that the equilibria are ‘attracting’ or ‘repelling’ (stable and unstable respectively).

It turns out that one cannot ‘overshoot’ the stable equilibrium and ‘oscillate’ around it. We will see later on why. Figure 2 shows the system time trajectories.

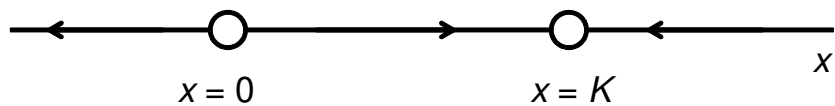

Figure 1: The phase line of the logistic equation, Equation (1.1)

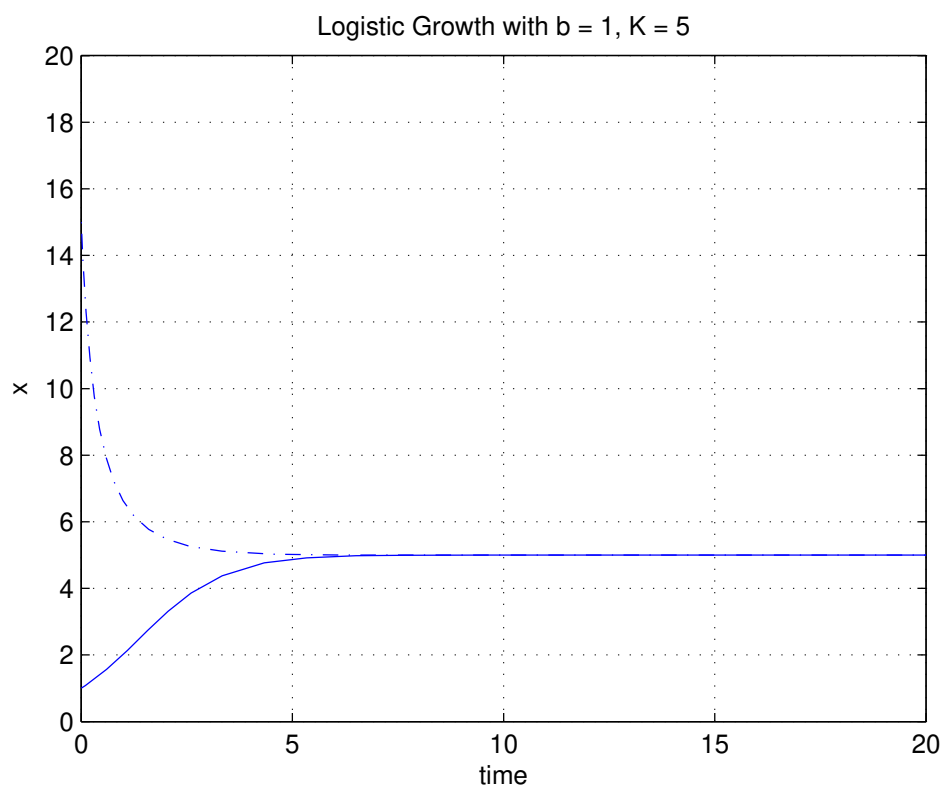

Figure 2: The time evolution of the logistic equation for  $b = 1$ ,  $K = 5$ .

## A simple pendulum

The dynamics of the simple pendulum shown in Figure 3 can be derived using Newton's second law of motion, to give

$$m\ell\ddot{\theta} = -mg \sin \theta - k\ell\dot{\theta}$$

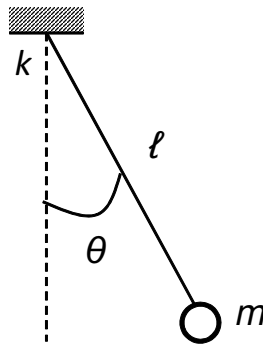

Figure 3: A simple pendulum

If we let  $x_1 = \theta$  and  $x_2 = \dot{\theta}$ , this can be written in state-space as

$$\begin{aligned}\dot{x}_1 &= x_2 \\ \dot{x}_2 &= -\frac{g}{\ell} \sin x_1 - \frac{k}{m} x_2\end{aligned}$$

Solving this set of differential equations is definitely not easy. Instead, let's consider the properties of the right hand side.

This system has several equilibria, satisfying

$$x_2 = 0 \text{ and } \sin x_1 = 0$$

This means that every point  $(n\pi, 0)$  is an equilibrium, for any  $n \in \mathbb{Z}$ . Out of these equilibria only two are distinct: the vertically upwards and the vertically downwards. Intuitively, small perturbations about the top equilibrium will cause the pendulum to swing far away, while small perturbations about the  $(0, 0)$  equilibrium will not cause such large deviations - this is a matter of *stability* which we will discuss in detail in the next few lectures.

The *phase-plane* has axes  $x_1$  and  $x_2$  and trajectories on it are parameterized by time. If we fill in the phase plane by arrows, the picture shown in Figure 4 emerges.

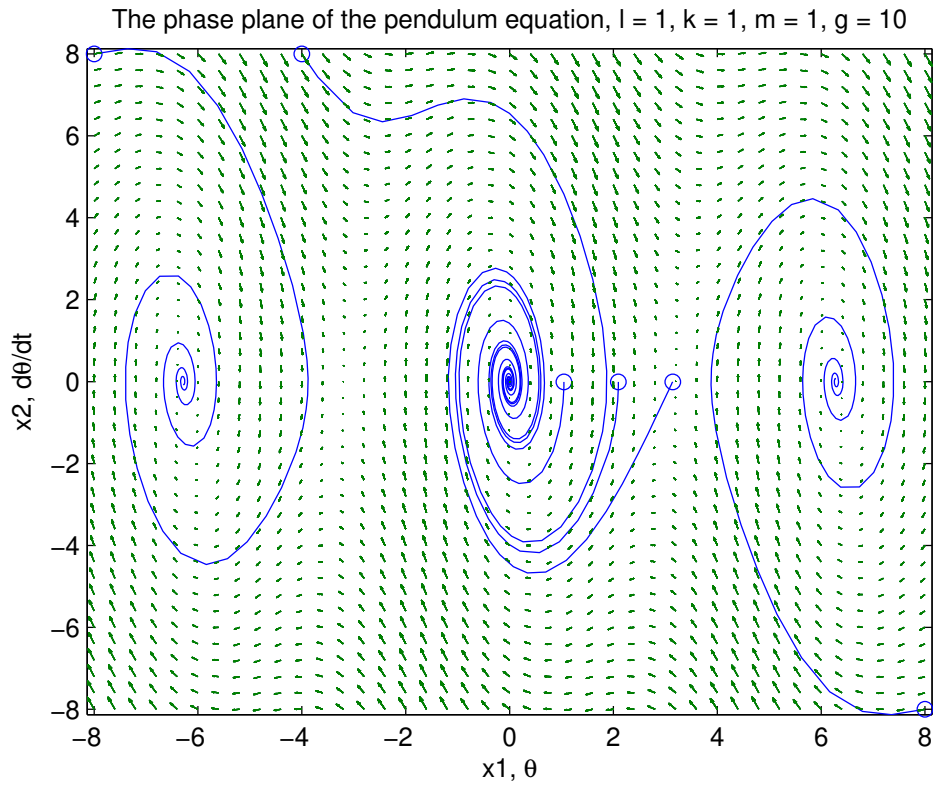

Figure 4: Pendulum phase plane with  $k = 1, m = 1, \ell = 1, g = 10$ .

With friction removed, the above equations read

$$\begin{aligned}\dot{x}_1 &= x_2 \\ \dot{x}_2 &= -\frac{g}{\ell} \sin x_1\end{aligned}$$

This system is *conservative* - the phase plane looks like Figure 5. What are the key characteristics?

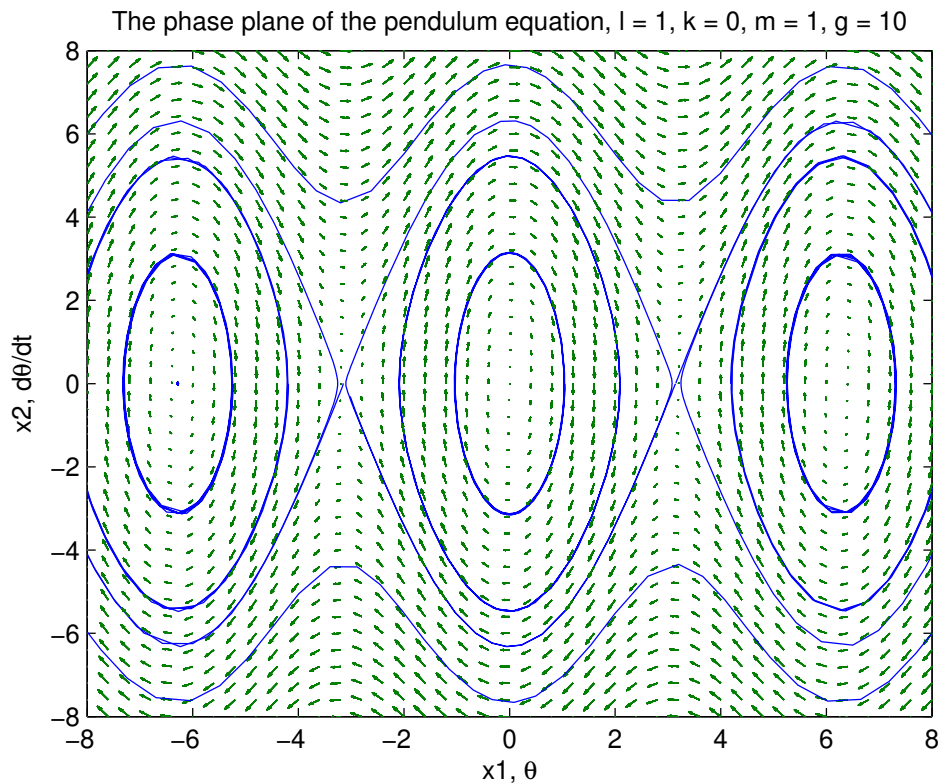

Figure 5: Pendulum phase plane with  $k = 0, m = 1, \ell = 1, g = 10$ .

### Glycolytic oscillations

Consider a model of glycolysis which involves turning glucose (sugar) into energy compounds, such as ATP. A simple model takes the form

$$\begin{aligned}\dot{x}_1 &= -x_1 + ax_2 + x_1^2x_2 \\ \dot{x}_2 &= b - ax_2 - x_1^2x_2\end{aligned}$$

where  $x_1$  and  $x_2$  are concentrations of two intermediates. Let us simulate this system for different parameter values and for different initial conditions - Figure 6 shows the system behaviour for one parameter set but with two different initial conditions. We will consider systems of this type in Lecture 5.

### The double pendulum

We have examined the behaviour of the single pendulum - let us now consider the double pendulum shown in Figure 7A.

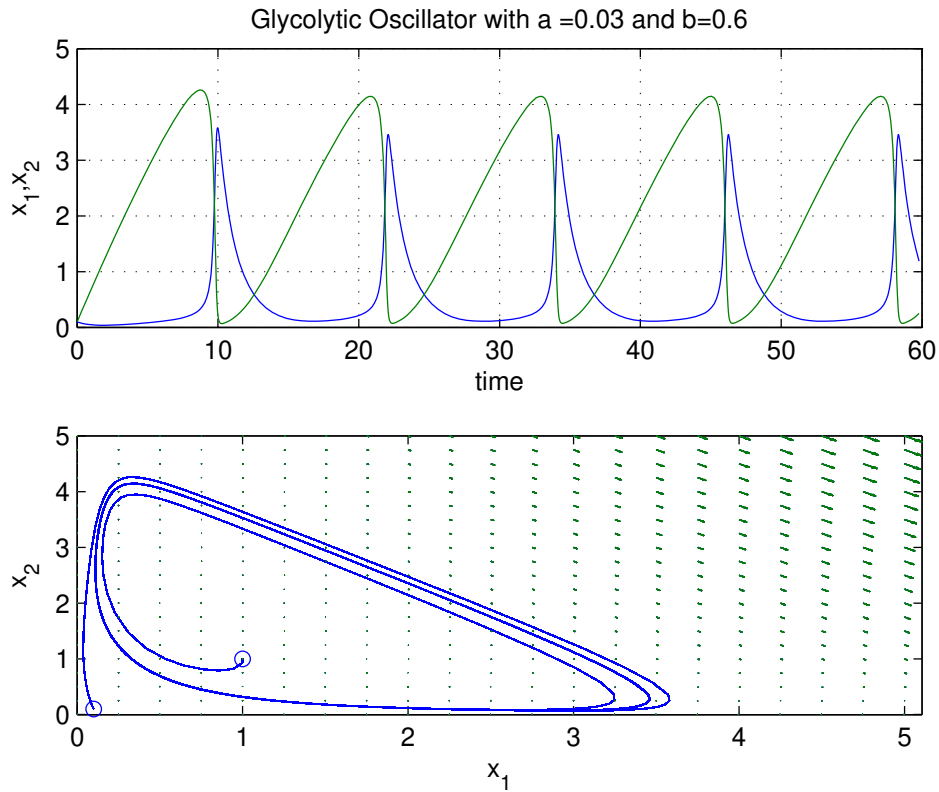

Figure 6: The glycolytic oscillator with  $a = 0.03$  and  $b = 0.6$ .

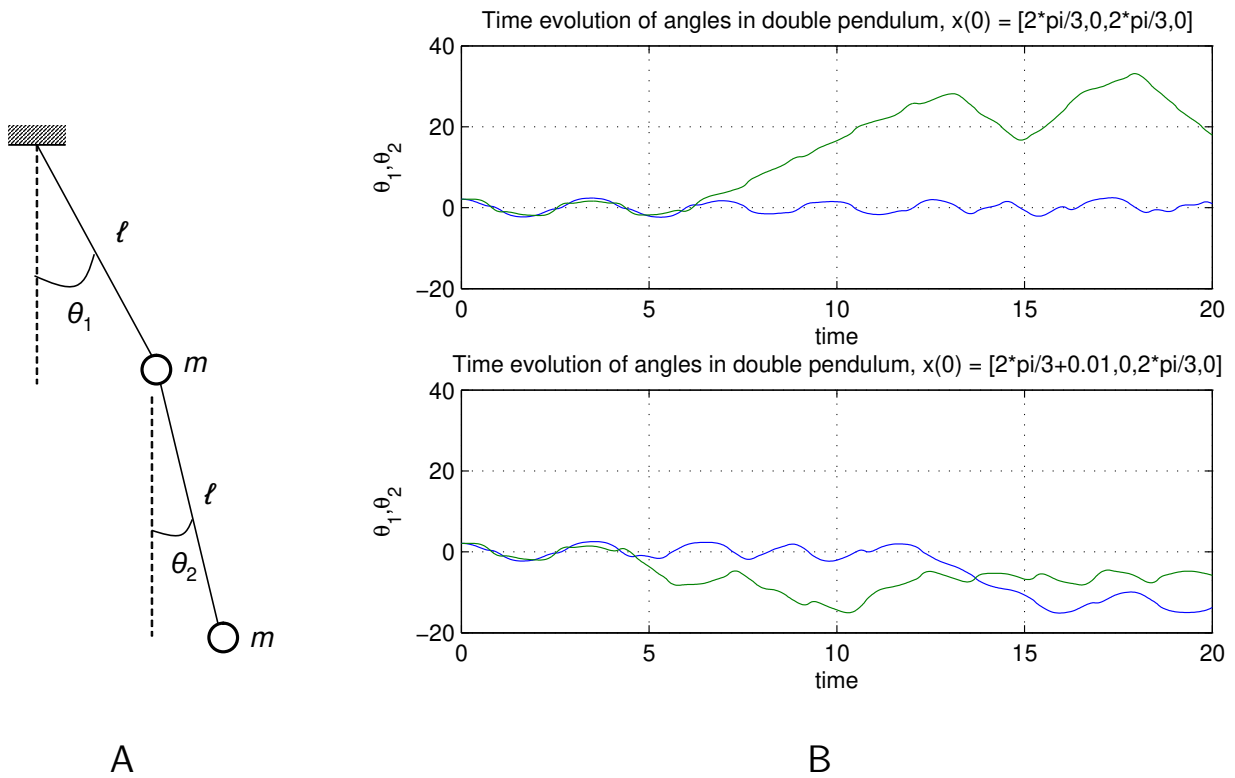

Figure 7: A: Double pendulum. B: Simulations for nearby initial conditions

Modelling this is beyond the scope of this course. Simulations of this system from two sets of initial conditions with zero velocities but very close to each other are shown in Figure 7B. What do you observe?

### The Mandelbrot set

The last example we will discuss concerns a *discrete time system*. Consider the following map:

$$z_{k+1} = z_k^2 + c$$

where  $z_k \in \mathbb{C}$  (i.e. is complex) and  $c \in \mathbb{C}$ . Sometimes this is written as

$$z \mapsto z^2 + c$$

Let's consider how  $|z_k|$  changes with various values of  $c$ , always starting from the same initial condition,  $z_0 = 0$ .

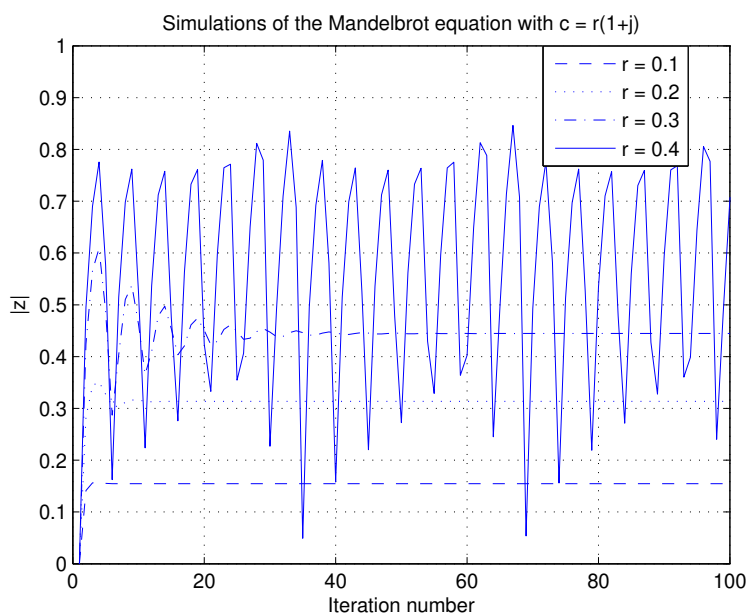

A

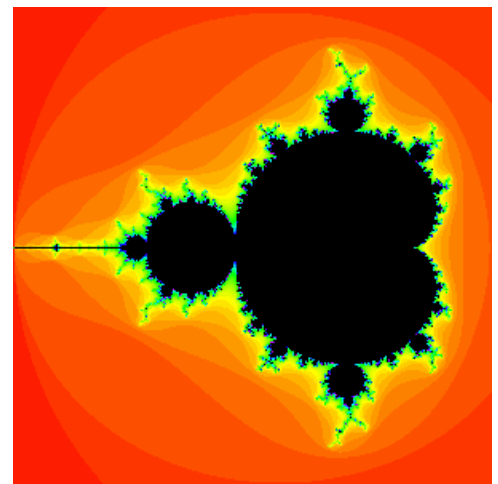

B

Figure 8: A: Simulations of the Mandelbrot equation with  $c = r(1 + j)$  for different values of  $r$ . B: The Mandelbrot set

## 1.2 Terminology, Notation and Relevant Background

Having seen some examples, before we proceed, we should remind ourselves of some important facts and introduce some new topics.

### 1.2.1 Eigenvalues and Eigenvectors

Recall that the eigenvalues and eigenvectors of a matrix  $\mathbf{A} \in \mathbb{R}^{n \times n}$  satisfy

$$\mathbf{A}\mathbf{v} = \lambda\mathbf{v}, \quad \mathbf{v} \neq \mathbf{0}$$

The eigenvalues can be found by solving the polynomial equation  $\det(\lambda\mathbf{I} - \mathbf{A}) = 0$ , and the corresponding eigenvectors can be found by solving the equation  $\mathbf{A}\mathbf{v}_i = \lambda_i\mathbf{v}_i$  for each eigenvalue  $\lambda_i$ . There are always  $n$  eigenvalues  $\lambda \in \mathbb{C}$ , and complex eigenvalues come in complex conjugate pairs. If the eigenvalues  $\lambda_i$ ,  $i = 1, \dots, n$  are distinct (i.e. different from each other) then the corresponding eigenvectors  $\mathbf{v}_i$  are linearly independent, and hence span the whole of  $\mathbb{R}^n$ , i.e., any  $\mathbf{x} \in \mathbb{R}^n$  can be written as

$$\mathbf{x} = c_1\mathbf{v}_1 + \dots + c_n\mathbf{v}_n$$

for some (possibly complex) scalars  $c_1, \dots, c_n$ . If some of the eigenvalues are repeated, then sometimes one cannot obtain  $n$  linearly independent eigenvectors.

Suppose we have computed a complete set of eigenvalues  $\lambda_i \in \mathbb{C}$  and there exists a complete set of eigenvectors  $\mathbf{v}_i$  spanning  $\mathbb{R}^n$  such that

$$\mathbf{A}\mathbf{v}_i = \lambda_i\mathbf{v}_i, \quad \mathbf{v}_i \neq \mathbf{0}$$

We create two new matrices:

$$\mathbf{\Lambda} = \begin{bmatrix} \lambda_1 & 0 & \cdots & 0 \\ 0 & \lambda_2 & & 0 \\ \vdots & & \ddots & 0 \\ 0 & 0 & \cdots & \lambda_n \end{bmatrix}, \quad \mathbf{V} = \begin{bmatrix} \vdots & \vdots & & \vdots \\ \mathbf{v}_1 & \mathbf{v}_2 & \cdots & \mathbf{v}_n \\ \vdots & \vdots & & \vdots \end{bmatrix}$$

Then

$$\mathbf{AV} = \mathbf{V}\mathbf{\Lambda}$$

and therefore

$$\mathbf{A} = \mathbf{V}\mathbf{\Lambda}\mathbf{V}^{-1}, \quad \mathbf{\Lambda} = \mathbf{V}^{-1}\mathbf{A}\mathbf{V}$$

For the case that a  $2 \times 2$  real matrix  $A$  has 2 complex eigenvalues  $\lambda = a + jb$  and  $\bar{\lambda} = a - jb$  and eigenvectors  $\mathbf{v} = \mathbf{u} + j\mathbf{w}$  and  $\bar{\mathbf{v}} = \mathbf{u} - j\mathbf{w}$ , another representation of  $\mathbf{A}$  takes the form

$$\mathbf{V}^{-1}\mathbf{A}\mathbf{V} = \begin{bmatrix} a & -b \\ b & a \end{bmatrix}$$

with

$$\mathbf{V} = [\mathbf{w}, \mathbf{u}].$$

**Example 1.1.** Consider the matrix

$$\begin{bmatrix} 3 & -2 \\ 1 & 1 \end{bmatrix}$$

with eigenvalues  $\lambda = 2 + j$  and  $\bar{\lambda} = 2 - j$  and corresponding eigenvectors  $[1 + j, 1]^\top$  and  $[1 - j, 1]^\top$ . One could, in principle represent the matrix as:

$$\begin{bmatrix} 3 & -2 \\ 1 & 1 \end{bmatrix} = \begin{bmatrix} 1+j & 1-j \\ 1 & 1 \end{bmatrix} \begin{bmatrix} 2+j & 0 \\ 0 & 2-j \end{bmatrix} \begin{bmatrix} 1+j & 1-j \\ 1 & 1 \end{bmatrix}^{-1}$$

To avoid complex numbers on the right hand side, we can represent it as

$$\begin{bmatrix} 3 & -2 \\ 1 & 1 \end{bmatrix} = \begin{bmatrix} 1 & 1 \\ 0 & 1 \end{bmatrix} \begin{bmatrix} 2 & -1 \\ 1 & 2 \end{bmatrix} \begin{bmatrix} 1 & 1 \\ 0 & 1 \end{bmatrix}^{-1}$$

The latter will be handy in the sequel.

## 1.2.2 Linear Autonomous Systems

Recall that a scalar ODE of the form  $\dot{x} = ax$  with initial conditions  $x(0) = x_0$  admits a solution of the form  $x(t) = e^{at}x_0$ . In the vector case, a set of linear ODEs of the form

$$\dot{\mathbf{x}} = \mathbf{A}\mathbf{x} \tag{1.2}$$

where  $\mathbf{x} \in \mathbb{R}^n$  is a vector and  $\mathbf{A} \in \mathbb{R}^{n \times n}$  a matrix, admits a solution in terms of a *matrix exponential*:

$$e^{\mathbf{A}} = \sum_{k=0}^{\infty} \frac{\mathbf{A}^k}{k!}$$

where  $\mathbf{A}^0 = \mathbf{I}$ , the Identity matrix. Based on this definition, we can show that  $\frac{d}{dt}(e^{t\mathbf{A}}) = \mathbf{A}e^{t\mathbf{A}} = e^{t\mathbf{A}}\mathbf{A}$ , and hence that

$$\mathbf{x}(t) = e^{t\mathbf{A}}\mathbf{x}(0)$$

is the solution of (1.2). But how can we compute this matrix exponential?

### 1.2.3 The matrix exponential

In the  $n$ -dimensional case, to calculate the matrix exponential, notice that

$$e^{\begin{bmatrix} \lambda_1 & 0 & 0 \\ 0 & \ddots & 0 \\ 0 & 0 & \lambda_n \end{bmatrix}} = \begin{bmatrix} e^{\lambda_1} & 0 & 0 \\ 0 & \ddots & 0 \\ 0 & 0 & e^{\lambda_n} \end{bmatrix}, \quad e^{\begin{bmatrix} \mathbf{A} & \mathbf{0} \\ \mathbf{0} & \mathbf{B} \end{bmatrix}} = \begin{bmatrix} e^{\mathbf{A}} & \mathbf{0} \\ \mathbf{0} & e^{\mathbf{B}} \end{bmatrix}$$

if  $\mathbf{A}$  and  $\mathbf{B}$  are square. Hence, if  $\mathbf{A}$  is diagonalizable,

$$e^{\mathbf{A}} = e^{\mathbf{V}\mathbf{\Lambda}\mathbf{V}^{-1}} = \mathbf{V}e^{\mathbf{\Lambda}}\mathbf{V}^{-1} = \mathbf{V}\text{diag}\{e^{\lambda_i}\}\mathbf{V}^{-1}$$

To see the middle step, expand the matrix exponential in series, using the definition above:

$$\begin{aligned} e^{\mathbf{V}\mathbf{\Lambda}\mathbf{V}^{-1}} &= \sum_{k=0}^{\infty} \frac{(\mathbf{V}\mathbf{\Lambda}\mathbf{V}^{-1})^k}{k!} \\ &= \mathbf{I} + \mathbf{V}\mathbf{\Lambda}\mathbf{V}^{-1} + \frac{1}{2!}\mathbf{V}\mathbf{\Lambda}\mathbf{V}^{-1}\mathbf{V}\mathbf{\Lambda}\mathbf{V}^{-1} + \dots \\ &= \mathbf{V} \left( \mathbf{I} + \mathbf{\Lambda} + \frac{1}{2!}\mathbf{\Lambda}^2 + \dots \right) \mathbf{V}^{-1} = \mathbf{V}e^{\mathbf{\Lambda}}\mathbf{V}^{-1} \end{aligned}$$

**Example 1.2.** Consider the system  $\dot{\mathbf{x}} = \mathbf{A}\mathbf{x}$  with

$$\mathbf{A} = \begin{bmatrix} -1 & 3 \\ 0 & 2 \end{bmatrix}$$

which has eigenvalues  $\lambda_1 = -1$  and  $\lambda_2 = 2$  and corresponding eigenvectors  $[1, 0]^\top$  and  $[-1, 1]^\top$ . The matrix  $\mathbf{V}$  and its inverse are

$$\mathbf{V} = \begin{bmatrix} 1 & -1 \\ 0 & 1 \end{bmatrix}, \quad \mathbf{V}^{-1} = \begin{bmatrix} 1 & 1 \\ 0 & 1 \end{bmatrix}.$$

In this case,  $e^{t\mathbf{A}}$  can be computed as:

$$e^{t\mathbf{A}} = \mathbf{V} \begin{bmatrix} e^{-t} & 0 \\ 0 & e^{2t} \end{bmatrix} \mathbf{V}^{-1} = \begin{bmatrix} e^{-t} & e^{-t} - e^{2t} \\ 0 & e^{2t} \end{bmatrix}$$

If  $\mathbf{A}$  has complex eigenvalues, the above can be written as

$$e^{\mathbf{A}t} = e^{\mathbf{V} \begin{bmatrix} a & -b \\ b & a \end{bmatrix} \mathbf{V}^{-1}t} = \mathbf{V} e^{\begin{bmatrix} a & -b \\ b & a \end{bmatrix}t} \mathbf{V}^{-1} = \mathbf{V} \begin{bmatrix} e^a \cos b & -e^a \sin b \\ e^a \sin b & e^a \cos b \end{bmatrix} \mathbf{V}^{-1}$$

(The last step requires you to expand the exponential in series and collect terms.)

### 1.3 Different types of Dynamical Systems

In the beginning of this lecture we discussed how dynamical system models can describe different phenomena - most of the models were simple low dimensional systems. In this section we introduce the mathematical notation that will be of interest in the rest of this lecture course as well as some important facts.

Consider a set of  $n$  Ordinary Differential Equations of the form

$$\begin{aligned} \dot{x}_1 &= f_1(x_1, \dots, x_n) \\ &\vdots \\ \dot{x}_n &= f_n(x_1, \dots, x_n) \end{aligned} \tag{1.3}$$

where  $(\dot{\phantom{x}})$  denotes differentiation with respect to time and the variables  $x_1, \dots, x_n$  represent the *states* of a system, e.g. position/velocities in mechanical systems, concentrations of species in biological systems and populations of species

in an ecological system. We will assume that  $x_i(t)$  takes real values, i.e.  $x_i(t) \in \mathbb{R}$  where  $\mathbb{R}$  denotes the set of real numbers. Moreover, we will denote  $\mathbf{x} = [x_1, \dots, x_n]^\top$ , in which case  $\mathbf{x}(t) \in \mathbb{R}^n$ . Here each  $f_i : \mathbb{R}^n \rightarrow \mathbb{R}$ , i.e. has domain  $\mathbb{R}^n$  and takes values in  $\mathbb{R}$ . We may sometimes restrict the domain of  $\mathbf{f}$  to a subset  $D$  of  $\mathbb{R}^n$ , i.e.  $D \subseteq \mathbb{R}^n$ . In this case we can write  $\mathbf{f} : D \rightarrow \mathbb{R}^n$ .

System (1.3) can be written in a more compact way as follows

$$\dot{\mathbf{x}} = \mathbf{f}(\mathbf{x}) \quad (1.4)$$

with all differential equations stacked together. This system is **autonomous** in the sense that  $\mathbf{f}$  does not depend on time. The autonomous system (1.4) is called *linear* if  $\mathbf{f}(\mathbf{x}) = \mathbf{A}\mathbf{x}$ , where  $\mathbf{A} \in \mathbb{R}^{n \times n}$ , i.e. is an  $n \times n$  matrix with real entries.

Time-dependent systems (also called ‘nonautonomous’ systems) of the form

$$\dot{\mathbf{x}} = \mathbf{f}(\mathbf{x}, t)$$

have very interesting properties, most of which are beyond the scope of this course. See the tutorial sheet for an example!

Systems of the form

$$\dot{\mathbf{x}} = \mathbf{f}(\mathbf{x}; \boldsymbol{\mu}) \quad (1.5)$$

where  $\boldsymbol{\mu} \in \mathbb{R}^p$  is a vector of *parameters* are of great importance – here we are asking what is happening to the system (their equilibria and stability) as  $\boldsymbol{\mu}$  changes. *Bifurcations* will be studied in Lecture 7. C24 Perturbation methods will consider the case where  $\boldsymbol{\mu} \in \mathbb{R}^p$  is a small parameter.

Systems of the form

$$\dot{\mathbf{x}} = \mathbf{f}(\mathbf{x}, \mathbf{u}) \quad (1.6)$$

where  $\mathbf{u} \in \mathbb{R}^m$  is a control input are beyond the scope of this course and are discussed in ‘C21 Nonlinear Systems’.

Lastly, systems described by *maps* or *difference equations* of the form

$$\mathbf{x} \mapsto \mathbf{g}(\mathbf{x}; \boldsymbol{\mu}) \quad (1.7)$$

such as the Mandelbrot set will be studied in Lecture 8. The above equation means that  $\mathbf{x}_{k+1} = \mathbf{g}(\mathbf{x}_k; \boldsymbol{\mu})$ , which is the notation we will use in the sequel.

We note here that while in differential equation theory we are interested in specific solutions given initial conditions, in dynamical systems we are interested in the behaviour of families of solutions without actually solving the differential equations. Geometry will play a key role in the rest of this lecture course.

A solution to either (1.5) or (1.7) is a map from some time interval  $[0, T]$  into  $\mathbb{R}^n$ , i.e.  $\mathbf{x} : [0, T] \rightarrow \mathbb{R}^n$  such that

$$\dot{\mathbf{x}}(t) = \mathbf{f}(\mathbf{x}(t); \boldsymbol{\mu}). \quad (1.8)$$

This map can be thought of geometrically as a curve in  $\mathbb{R}^n$ , as we have seen in the examples before; the RHS of (1.5) gives the *velocity* at  $\mathbf{x}(t)$  and is a vector *tangent to* every point on the curve.

## Existence and Uniqueness of Solutions

(An aside, not examinable!)

Let us return now to the nonlinear differential equation (1.4). Throughout these notes we will assume that an initial condition is given at  $t = 0$ , which will be denoted by  $\mathbf{x}(0) = \mathbf{x}_0$ , where  $\mathbf{x}_0 \in \mathbb{R}^n$ .

One question that we have not discussed up to now is whether solutions exist and are unique. Could something awkward happen?

**Example 1.3.**  $\dot{x} = 1 + x^2$  has solution  $x(t) = \tan(t + c)$ , but this has a singularity at every time  $t$  such that  $t + c = k\pi + \pi/2$ ,  $k = 0, \pm 1, \pm 2, \dots$

**Example 1.4.**  $\dot{x} = 3x^{2/3}$  from  $x(0) = 0$  has two solutions:  $x(t) = 0$  and  $x(t) = t^3$ , thus solutions exist but are not unique.

What is wrong with (or special about) these systems? Let's define the *Euclidean norm* on  $\mathbb{R}^n$  to be  $\|\mathbf{x}\| = (x_1^2 + \dots + x_n^2)^{1/2}$ .

**Definition 1.1.** A function  $\mathbf{f} : \mathbb{R}^n \rightarrow \mathbb{R}^n$  is Lipschitz continuous in a region

$D$  if there exists a scalar  $L > 0$  such that for all  $\mathbf{x}, \mathbf{y} \in D$

$$\|\mathbf{f}(\mathbf{x}) - \mathbf{f}(\mathbf{y})\| \leq L\|\mathbf{x} - \mathbf{y}\|.$$

In this case  $L$  is called the *Lipschitz* constant of  $\mathbf{f}$ .

Suppose  $\mathbf{f}$  is Lipschitz continuous in a region  $D$  which contains the initial condition, with Lipschitz constant  $L$ . Let us define  $D$  to be a 'ball' of radius  $\delta$  around  $\mathbf{x}_0$ :

$$D = \{\mathbf{x} \in \mathbb{R}^n : \|\mathbf{x} - \mathbf{x}_0\| \leq \delta\}$$

Also, let us assume that for all  $\mathbf{x} \in D$ , the function  $\mathbf{f}(\mathbf{x})$  is bounded as follows:  $\|\mathbf{f}(\mathbf{x})\| \leq M$ . Then  $\dot{\mathbf{x}} = \mathbf{f}(\mathbf{x})$  with  $\mathbf{x}(0) = \mathbf{x}_0$  has a unique solution for  $t \in [-\epsilon, \epsilon]$  as long as  $0 < \epsilon < \min(1/L, \delta/M)$ . Moreover, if  $\mathbf{y}$  is the solution for  $\mathbf{x}(0) = \mathbf{y}_0$  and  $\mathbf{z}$  is the solution for  $\mathbf{x}(0) = \mathbf{z}_0$  over the time interval  $t \in [0, T]$  then the following holds:

$$\|\mathbf{y}(t) - \mathbf{z}(t)\| \leq e^{LT}\|y_0 - z_0\|, \text{ for all } t \in [0, T].$$

The above result says that solutions exist and are unique for finite amounts of time as long as  $\mathbf{f}(\mathbf{x})$  is Lipschitz continuous; and that solutions for nearby initial conditions do not grow faster than an exponential rate.

In the two examples discussed above, the function  $1 + x^2$  is not Lipschitz continuous for all  $x$  and the function  $3x^{2/3}$  is not Lipschitz continuous in any region  $D$  containing  $x = 0$ .

For the rest of this lecture course we will assume that solutions exist and are unique locally, i.e. we will assume that the vector fields are sufficiently smooth to allow this.

Is it now obvious why the logistic growth model cannot oscillate? If it did, then at a point on the phase-line there would be two solutions: one going 'left' and one 'right', which violates uniqueness of solutions.

## 2 Equilibria and Stability

As emphasized in the previous lecture, the aim of Dynamical Systems is to understand how systems of differential equations behave. But you may recall from the P1 course on Differential Equations, that nonlinear ODEs seldom have analytic solutions. How is one supposed to understand the properties of such systems without finding solutions to them?

The aim of Dynamical Systems theory is to obtain qualitative information about the behaviour of a differential/difference equation model, without solving it. Questions of interest are, e.g. whether the asymptotic behaviour of the system is periodic, attracting or chaotic, etc. Most of the analysis in Dynamical Systems is geometric rather than analytic.

The first idea that needs to be understood concerns the notion of an equilibrium solution.

### 2.1 Equilibrium Solutions

#### Flows

Consider a dynamical system of the form

$$\dot{\mathbf{x}} = \mathbf{f}(\mathbf{x}) \quad (2.1)$$

where  $\mathbf{x}(t) \in \mathbb{R}^n$ . An *equilibrium solution* of this system is a solution  $\mathbf{x}^* \in \mathbb{R}^n$  which is constant - i.e.  $\dot{\mathbf{x}}^* = \mathbf{0}$ . Other names for  $\mathbf{x}^*$  are 'fixed point', 'stationary point', 'rest point', 'critical point' and 'steady-state'. This necessarily means that

$$\mathbf{f}(\mathbf{x}^*) = \mathbf{0}$$

which is a set of algebraic relationships in the elements,  $x_i^*$ ,  $i = 1, \dots, n$ , of  $\mathbf{x}$  that can be solved either analytically or numerically. Note that these relationships will be nonlinear, so sometimes [root finding](#) methods need to be used. Because the equations are nonlinear, several isolated solutions  $\mathbf{x}^*$  may exist. At all of these points, the flow is zero ('everything stops there') so they are interesting points at which to consider the asymptotic behaviour of solutions (i.e. as time goes to infinity).

For 1-D systems, both the equilibria and their behaviour are easy to understand – recall the logistic equation from Lecture 1. Higher-dimensional systems may have a much richer behaviour around their equilibria as we have already seen. How can we understand this behaviour?

## Maps

In the case of a difference equation

$$\mathbf{x}_{k+1} = \mathbf{F}(\mathbf{x}_k)$$

the equilibrium solutions are, again, those that do not change under the discrete update law, i.e.  $\mathbf{x}^* \in \mathbb{R}^n$  needs to satisfy

$$\mathbf{x}^* = \mathbf{F}(\mathbf{x}^*)$$

This is another algebraic set of equations which can be solved using root-finding algorithms. However, it may seem to be more difficult to understand the geometric properties of discrete-time dynamical systems as solutions ‘jump’ from one point to the next under the map  $\mathbf{F} : \mathbb{R}^n \rightarrow \mathbb{R}^n$ . This is why even the simplest one-dimensional system can exhibit quite an exotic behaviour.

## 2.2 Stability

Once the equilibria are found, the next question to ask is whether they are *stable*. We consider here the case of flows – the case of maps is very similar.

### Stability of flow equilibria

An equilibrium solution  $\mathbf{x}^*$  is *stable*, if (roughly speaking) system evolutions with initial conditions near to  $\mathbf{x}^*$  stay close to  $\mathbf{x}^*$  for all times; and *asymptotically stable* if they don’t just stay close, **but converge to  $\mathbf{x}^*$  as  $t \rightarrow \infty$** .

**Definition 2.1.**  $\mathbf{x}^*$  is said to be *stable* if, given  $\epsilon > 0$ , there exists a  $\delta = \delta(\epsilon) > 0$  such that any other solution  $\mathbf{y}(t)$  of (2.1) satisfying  $|\mathbf{y}(0) - \mathbf{x}^*| < \delta$  then  $|\mathbf{y}(t) - \mathbf{x}^*| < \epsilon$  for  $t \geq 0$ . Otherwise, it is called *unstable*.  $\mathbf{x}^*$  is said to be *asymptotically stable* if it is stable and if there is a  $b > 0$  such that if  $|\mathbf{y}(0) - \mathbf{x}^*| < b$  then  $\lim_{t \rightarrow \infty} |\mathbf{y}(t) - \mathbf{x}^*| = 0$ .

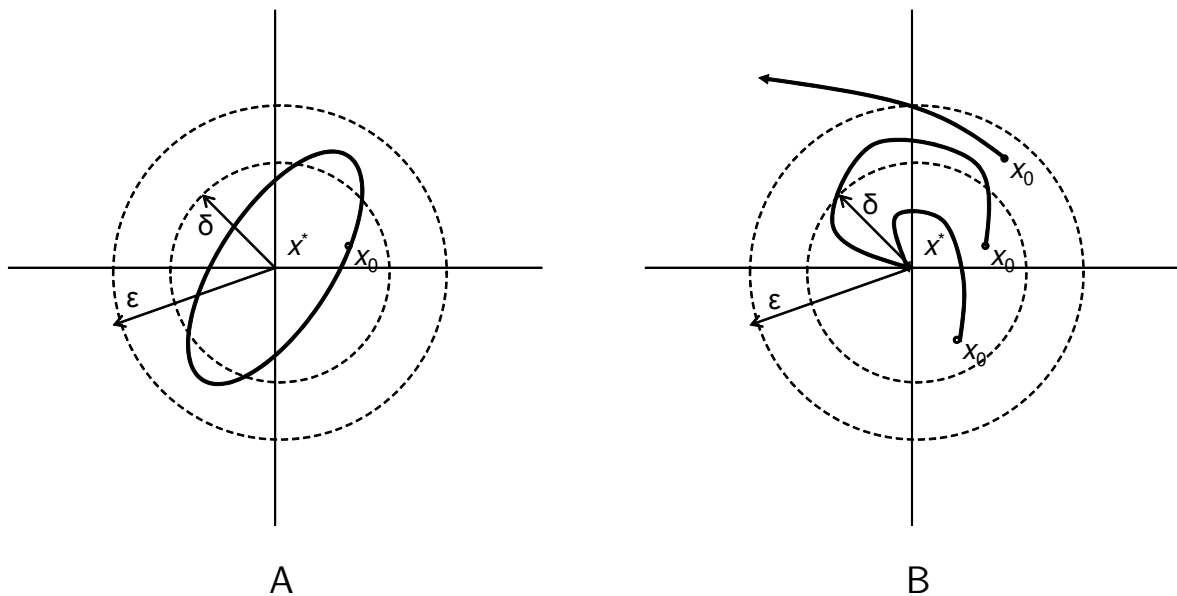

Figure 9: Stability (A) and Asymptotic Stability (B).

Note that the ‘for all  $\epsilon > 0$  there exists a  $\delta > 0$ ’ formulation is very common in topology and dynamical systems. It is a ‘game’ between you, that is trying to show stability, and someone else – an opponent. (S)he gets to pick  $\epsilon$  and you have to find a  $\delta$  (which may depend on  $\epsilon$ ) so that a trajectory that starts a distance  $\delta$  from the equilibrium stays within a distance  $\epsilon$  of it. Therefore the solution is allowed to move away from the equilibrium, but not too far.

Lastly, an equilibrium  $\mathbf{x}^*$  is said to be *exponentially stable* if  $\mathbf{x}^*$  is asymptotically stable and there exist  $\alpha, \beta, \delta \in (0, \infty)$  such that if  $\|\mathbf{y}(0) - \mathbf{x}^*\| < \delta$  then  $\|\mathbf{y}(t) - \mathbf{x}^*\| \leq \alpha e^{-\beta t} \|\mathbf{y}(0) - \mathbf{x}^*\|$  for  $t \geq 0$ .

## 2.3 Linear Systems

Before we consider the case of nonlinear systems, let us first consider the case of a linear system of the form

$$\dot{\mathbf{x}} = \mathbf{A}\mathbf{x}$$

### 2.3.1 Second order systems

#### Uncoupled Case

If the individual components of the state vector have uncoupled dynamics, we can write

$$\begin{aligned}\dot{x}_1 &= \alpha_1 x_1 \\ \dot{x}_2 &= \alpha_2 x_2\end{aligned}$$

These differential equations can be solved directly to give

$$\begin{aligned}x_1(t) &= e^{\alpha_1 t} x_1(0) \\ x_2(t) &= e^{\alpha_2 t} x_2(0)\end{aligned}$$

Where do trajectories lie? A simple calculation reveals that they satisfy

$$x_1 = c x_2^{\alpha_1/\alpha_2}$$

The *phase-plane* in this case is a picture of these curves on the  $x_1, x_2$  plane; we use arrows to denote the direction of motion as time progresses. The equilibrium point, is (of course) the origin, and depending on the values of  $\alpha$ , we can argue whether solutions on the axes approach or leave the origin; the rest of the phase-plane can then be filled by trajectories.

**Example 2.1.** For the case

$$\begin{aligned}\dot{x}_1 &= -x_1 \\ \dot{x}_2 &= 2x_2\end{aligned}$$

the trajectories satisfy  $y = k/x^2$  (for  $x = x_1$  and  $y = x_2$ ). The phase portrait is shown in Figure 10.

#### Coupled Case

In the coupled case, one may consider the  $2 \times 2$  linear autonomous system:

$$\begin{aligned}\dot{x}_1 &= ax_1 + bx_2 \\ \dot{x}_2 &= cx_1 + dx_2\end{aligned}$$

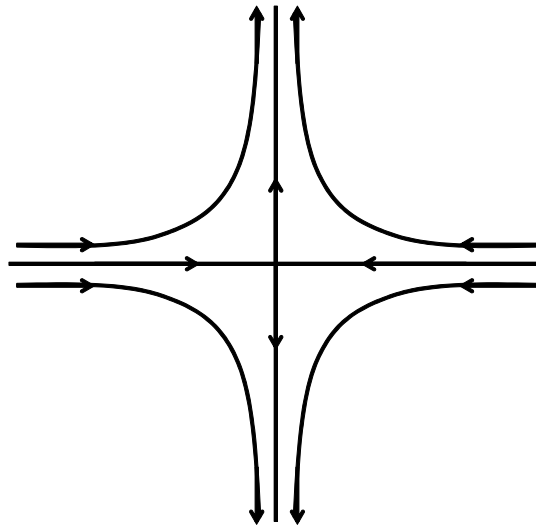

Figure 10: The phase plane of a decoupled system.

which we can write as  $\dot{\mathbf{x}} = \mathbf{A}\mathbf{x}$  with

$$\mathbf{A} = \begin{bmatrix} a & b \\ c & d \end{bmatrix}$$

Let us find the eigenvalues  $\lambda_i$  of  $\mathbf{A}$ . These satisfy

$$\lambda^2 - (a + d)\lambda + (ad - bc) = 0$$

Denoting by  $\tau$  the Trace of  $\mathbf{A}$ , i.e.  $\tau = a + d$  (the sum of diagonal elements) and by  $D$  the determinant of  $\mathbf{A}$ , i.e.  $D = ad - bc$  we have that

$$\begin{aligned} \lambda_1 + \lambda_2 &= \tau \\ \lambda_1 \lambda_2 &= D \end{aligned}$$

If the eigenvalues are distinct and nonzero, then

$$\mathbf{x}(t) = c_1 e^{\lambda_1 t} \mathbf{v}_1 + c_2 e^{\lambda_2 t} \mathbf{v}_2$$

where  $\mathbf{v}_1, \mathbf{v}_2$  are the eigenvectors corresponding to the eigenvalues  $\lambda_1, \lambda_2$  of  $\mathbf{A}$ .

Consider an initial condition of the form

$$\mathbf{x}(0) = c_1 \mathbf{v}_1 + c_2 \mathbf{v}_2$$

then the solution is of the form

$$\begin{aligned}
 \mathbf{x}(t) &= e^{t\mathbf{A}}\mathbf{x}(0) \\
 &= \left( \mathbf{I} + t\mathbf{A} + \frac{t^2}{2!}\mathbf{A}^2 + \dots \right) (c_1\mathbf{v}_1 + c_2\mathbf{v}_2) \\
 &= c_1 \left( 1 + t\lambda_1 + \frac{t^2}{2!}\lambda_1^2 + \dots \right) \mathbf{v}_1 + c_2 \left( 1 + t\lambda_2 + \frac{t^2}{2!}\lambda_2^2 + \dots \right) \mathbf{v}_2 \\
 &= c_1 e^{\lambda_1 t} \mathbf{v}_1 + c_2 e^{\lambda_2 t} \mathbf{v}_2
 \end{aligned}$$

The following points are worth mentioning:

- If  $\text{Re}(\lambda) < 0$  then the corresponding contribution to the solution is **vanishing to zero**.
- If  $\text{Re}(\lambda) > 0$  then the corresponding contribution to the solution grows exponentially with time.
- If  $\text{Re}(\lambda) = 0$  then the corresponding contribution is constant with time.
- If  $\text{Im}(\lambda) \neq 0$  then the corresponding contribution **spirals around the zero equilibrium**.
- If  $\text{Im}(\lambda) = 0$  then the corresponding contribution does not spiral around the zero equilibrium.

Moreover, the solution  $\mathbf{x}(t)$  will tend to one of  $\mathbf{v}_i$  depending on the sign of  $\lambda$  if real - this can be seen by examining the solution, or by constructing a change of coordinates  $\mathbf{y} = \mathbf{V}^{-1}\mathbf{x}$  to turn  $\dot{\mathbf{x}} = \mathbf{A}\mathbf{x}$  into the normal form:

$$\dot{\mathbf{y}} = \mathbf{V}^{-1}\mathbf{A}\mathbf{V}\mathbf{y} = \begin{bmatrix} \lambda_1 & 0 \\ 0 & \lambda_2 \end{bmatrix} \mathbf{y}$$

which is uncoupled and therefore the  $y_i$  axes must be invariant; these axes correspond to the  $i$ th eigenvectors of the system.

We are now ready to classify fixed points in two dimensions:

1. **Saddle** This happens if  $\lambda_i \in \mathbb{R}$  and  $\lambda_1\lambda_2 < 0$ . The equilibrium is unstable and the shape of the saddle is controlled by the eigenvectors  $\mathbf{v}_i$ . The

normal form of a Saddle is a system with matrix

$$\mathbf{A} = \begin{bmatrix} \mu & 0 \\ 0 & \nu \end{bmatrix}$$

with  $\mu < 0 < \nu$ . The four non-zero trajectories that approach the origin as  $t \rightarrow \pm\infty$  are called *separatrices*. See Figure 11.

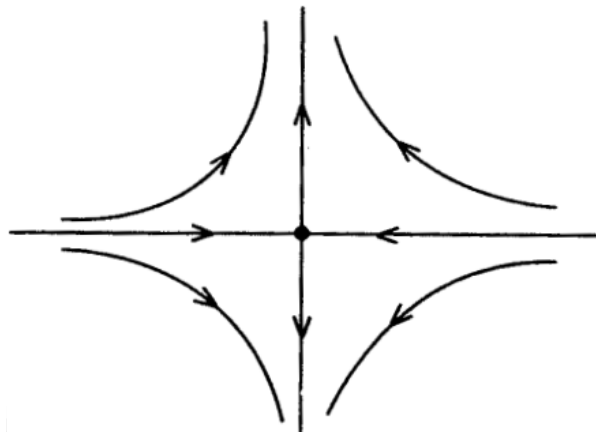

Figure 11: A Saddle.

2. **Stable Node** This happens if  $\lambda_i \in \mathbb{R}$  and  $\lambda_1 < 0$ ,  $\lambda_2 < 0$ . The equilibrium is (exponentially) stable and the shape of the stable node is controlled by the eigenvectors  $\mathbf{v}_i$ , with  $\mathbf{v}_1$  controlling the long term behaviour if  $|\lambda_1| < |\lambda_2|$ . The normal forms of a stable node are systems with matrices

$$\mathbf{A} = \begin{bmatrix} \mu & 0 \\ 0 & \nu \end{bmatrix}, \quad \mathbf{A} = \begin{bmatrix} \mu & 1 \\ 0 & \mu \end{bmatrix}$$

where  $\mu \leq \nu < 0$ . See Figure 12.

3. **Unstable Node** This happens if  $\lambda_i \in \mathbb{R}$  and  $\lambda_1 > 0$ ,  $\lambda_2 > 0$ . The equilibrium is unstable and the shape of the unstable node is controlled by the eigenvectors  $\mathbf{v}_i$ . The phase plane is the same as in the previous case, with all the arrows reversed.
4. **Centre** This happens if  $\text{Re } \lambda_i = 0$  and  $\text{Im } \lambda_i \neq 0$ . The equilibrium is 'neutrally stable'. The normal form is a system with the following  $\mathbf{A}$  matrix:

$$\mathbf{A} = \begin{bmatrix} 0 & -b \\ b & 0 \end{bmatrix}$$

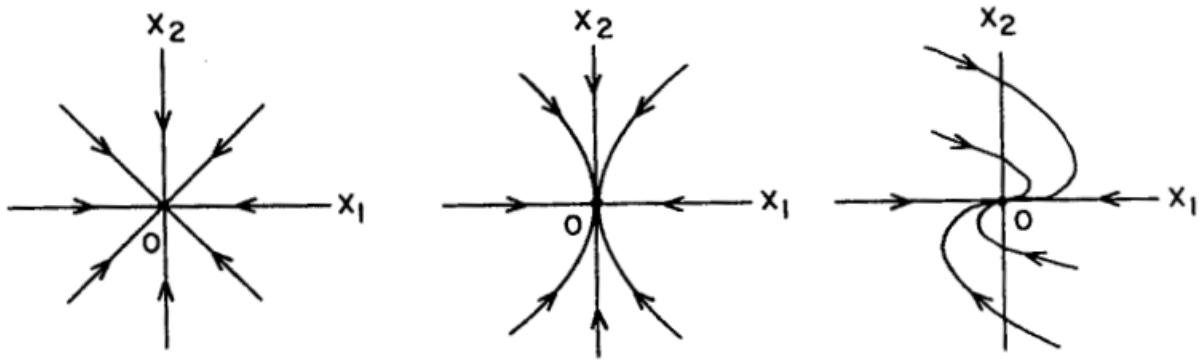

Figure 12: The different cases of a Stable Node. Left:  $\mu = \nu$ , generic case. Middle:  $\mu < \nu$ , generic case. Right: Degenerate case.

Trajectories of this system lie on circles of constant radius. See Figure 13.

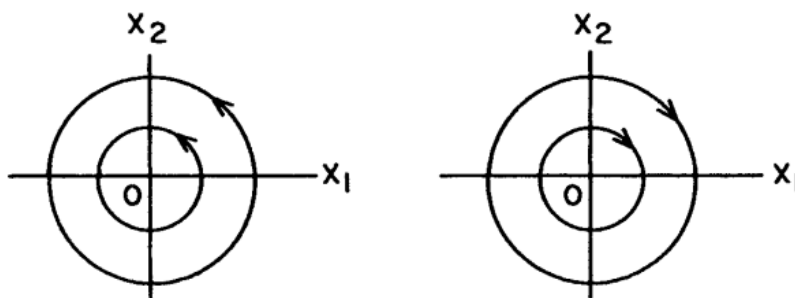

Figure 13: The different cases of a Centre. Left:  $b > 0$ . Right:  $b < 0$ .

5. **Stable Spiral** This happens if  $\text{Re } \lambda_i < 0$ ,  $\text{Im } \lambda_i \neq 0$ . The equilibrium is exponentially stable. The normal form is a system with the following  $\mathbf{A}$  matrix:

$$\mathbf{A} = \begin{bmatrix} a & -b \\ b & a \end{bmatrix}$$

with  $a < 0$ . In this case trajectories do not approach the origin in any eigen-direction. The direction of the spiral can be determined by the vector field. See Figure 14.

6. **Unstable Spiral** This happens if  $\text{Re } \lambda_i > 0$ ,  $\text{Im } \lambda_i \neq 0$ . The equilibrium is unstable and the phase plane is the same as in the previous case, with all the arrows reversed.

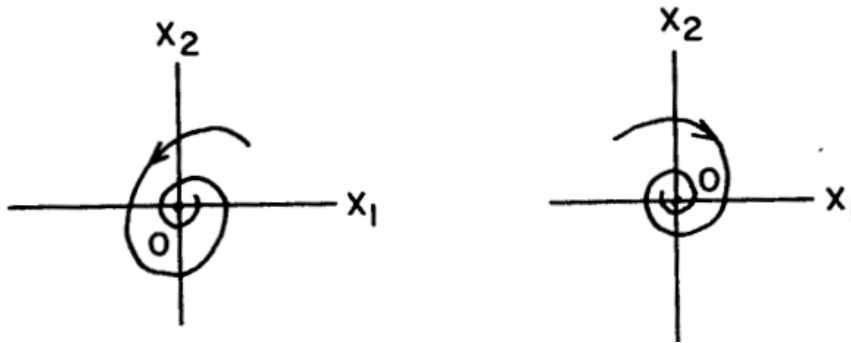

Figure 14: The different cases of a Stable Spiral. Left:  $b > 0$ . Right:  $b < 0$ .

There are also a number of borderline and degenerate cases which you will see in the examples paper. Finally, please note that a stable node or spiral is sometimes called a sink; an unstable node or focus is called a source.

To summarize, the solutions of the three types of systems we have seen are:

- $\dot{\mathbf{x}} = \begin{bmatrix} \mu & 0 \\ 0 & \nu \end{bmatrix} \mathbf{x}$  with  $\mathbf{x}(0) = \mathbf{x}_0$  has solution  $\mathbf{x}(t) = \begin{bmatrix} e^{\mu t} & 0 \\ 0 & e^{\nu t} \end{bmatrix} \mathbf{x}_0$
- $\dot{\mathbf{x}} = \begin{bmatrix} \mu & 1 \\ 0 & \mu \end{bmatrix} \mathbf{x}$  with  $\mathbf{x}(0) = \mathbf{x}_0$  has solution  $\mathbf{x}(t) = e^{\mu t} \begin{bmatrix} 1 & t \\ 0 & 1 \end{bmatrix} \mathbf{x}_0$
- $\dot{\mathbf{x}} = \begin{bmatrix} a & -b \\ b & a \end{bmatrix} \mathbf{x}$  with  $\mathbf{x}(0) = \mathbf{x}_0$  has solution  $\mathbf{x}(t) = e^{at} \begin{bmatrix} \cos bt & -\sin bt \\ \sin bt & \cos bt \end{bmatrix} \mathbf{x}_0$

**Example 2.2.** Consider the system

$$\dot{\mathbf{x}} = \begin{bmatrix} 0 & 2 \\ 1 & -1 \end{bmatrix} \mathbf{x}$$

The first step is to change coordinates, so as to bring the system into the normal form. The eigenvalues of  $\mathbf{A}$  are 1 and  $-2$ , found by solving

$$\lambda^2 + \lambda - 2 = 0 \Rightarrow (\lambda - 1)(\lambda + 2) = 0$$

The corresponding eigenvectors are  $[2 \ 1]^T$  and  $[-1 \ 1]^T$  respectively and so  $\mathbf{A}$  can be written as

$$\begin{bmatrix} 0 & 2 \\ 1 & -1 \end{bmatrix} = \begin{bmatrix} 2 & -1 \\ 1 & 1 \end{bmatrix} \begin{bmatrix} 1 & 0 \\ 0 & -2 \end{bmatrix} \overbrace{\begin{bmatrix} 2 & -1 \\ 1 & 1 \end{bmatrix}^{-1}}^{\mathbf{V}^{-1}}$$

Defining new coordinates as  $\mathbf{y} = \mathbf{V}^{-1}\mathbf{x}$ , the system becomes diagonal and therefore the  $[2, 1]^\top$  and the  $[-1, 1]^\top$  directions form two new axes: the former is an unstable direction (subspace), while the latter is a stable subspace – both are invariant. The phase portrait for this system is shown in Figure 15.

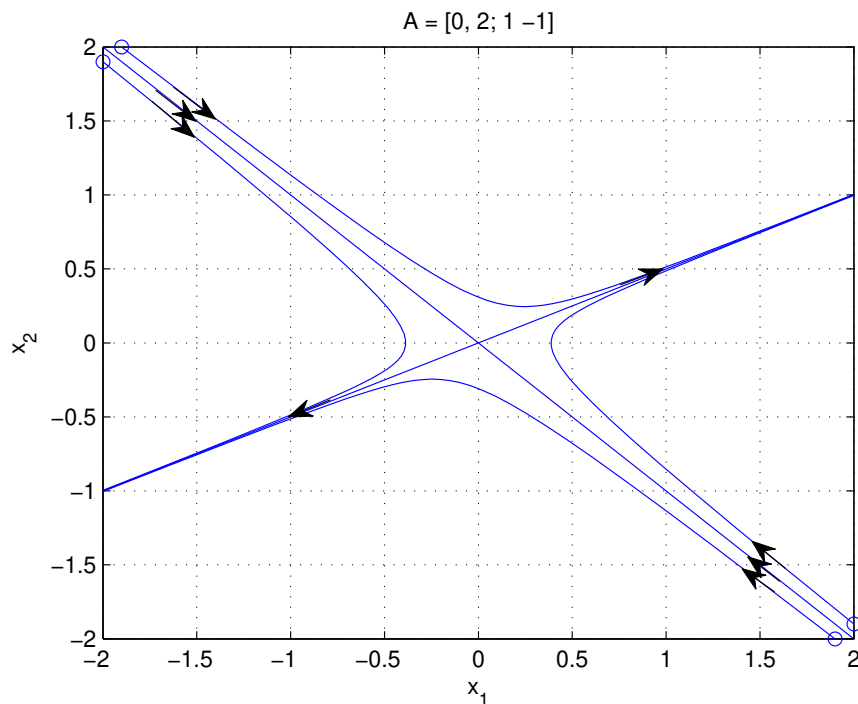

Figure 15: The phase plane of the system in Example 2.2.

Note that the solution can be written as

$$\begin{aligned} \mathbf{x}(t) &= \begin{bmatrix} 2 & -1 \\ 1 & 1 \end{bmatrix} \begin{bmatrix} e^t & 0 \\ 0 & e^{-2t} \end{bmatrix} \begin{bmatrix} 1/3 & 1/3 \\ -1/3 & 2/3 \end{bmatrix} \mathbf{x}(0) \\ &= \begin{bmatrix} 2/3e^t + 1/3e^{-2t} & -2/3e^{-2t} + 2/3e^t \\ -1/3e^{-2t} + 1/3e^t & 1/3e^t + 2/3e^{-2t} \end{bmatrix} \mathbf{x}(0) \end{aligned}$$

## Maps

In the case of maps, a linear discrete-time system takes the form (see Examples paper)

$$\mathbf{w}_{k+1} = \mathbf{A}\mathbf{w}_k$$

where  $\mathbf{A} \in \mathbb{R}^{n \times n}$ . In the examples paper you will develop the stability conditions for the case of maps.

## 2.4 Nonlinear Systems

Let us now turn our attention to (2.1). An approximation of the solution of (2.1) at a point near  $\mathbf{x}^*$  can be obtained by linearization, assuming that  $\mathbf{f}$  is differentiable. Let  $\mathbf{x} = \mathbf{x}^* + \mathbf{w}$ . Then

$$\dot{\mathbf{x}} = \dot{\mathbf{x}}^* + \dot{\mathbf{w}} = \mathbf{f}(\mathbf{x}^*) + D\mathbf{f}(\mathbf{x}^*)\mathbf{w} + \mathcal{O}(\|\mathbf{w}\|^2)$$

where  $D\mathbf{f}$  is the 'gradient' of  $\mathbf{f}$ , i.e. whose  $(i, j)$  element is  $\frac{\partial f_i}{\partial x_j}$  and  $\|\cdot\|$  is a norm on  $\mathbb{R}^n$ . The above simplifies to

$$\dot{\mathbf{w}} = D\mathbf{f}(\mathbf{x}^*)\mathbf{w} + \mathcal{O}(\|\mathbf{w}\|^2)$$

For solutions very close to  $\mathbf{x}^*$ , we consider only the *linear* system

$$\dot{\mathbf{w}} = D\mathbf{f}(\mathbf{x}^*)\mathbf{w} \triangleq \mathbf{A}\mathbf{w} \quad (2.2)$$

and the stability of the solution  $\mathbf{w} = 0$ . Recall that the solution of (2.2) is

$$\mathbf{w}(t) = e^{D\mathbf{f}(\mathbf{x}^*)t}\mathbf{w}(0)$$

and so  $\mathbf{w}(t)$  is asymptotically stable if all eigenvalues of  $D\mathbf{f}(\mathbf{x}^*)$  have negative real parts.

The question of how the stability of  $\mathbf{w} = \mathbf{0}$  in (2.2) is related to the stability of  $\mathbf{x} = \mathbf{x}^*$  in (2.1) is answered by the following theorem:

**Theorem 2.2.** *Suppose all eigenvalues of  $D\mathbf{f}(\mathbf{x}^*)$  have negative real parts. Then the equilibrium solution  $\mathbf{x} = \mathbf{x}^*$  of (2.1) is asymptotically stable.*

In fact there is a special name for an equilibrium  $\mathbf{x}^*$  with the property that the linearization about  $\mathbf{x}^*$  is a linear vector field with eigenvalues with non-zero real parts:

**Definition 2.3. (Hyperbolic Equilibrium)** Let  $\mathbf{x} = \mathbf{x}^*$  be an equilibrium of  $\dot{\mathbf{x}} = \mathbf{f}(\mathbf{x})$ . Then  $\mathbf{x}^*$  is called a *hyperbolic* fixed point if none of the eigenvalues of  $D\mathbf{f}(\mathbf{x}^*)$  have zero real part.

Roughly speaking, if an equilibrium is hyperbolic then the behaviour of the nonlinear system and the linearized system close to the equilibrium is very similar ('topologically equivalent'). Therefore, hyperbolic equilibria can be classified according to the eigenvalues of  $D\mathbf{f}(\mathbf{x}^*)$ .

Therefore, a simple way of understanding the properties of a vector field locally is to linearize the system about all the equilibria, analyze their behaviour separately, and draw the phase plane of the nonlinear system – unless an equilibrium is non-hyperbolic. In that case, not much can be said locally around that point – we will talk about this case more in Lecture 3.

**Example 2.3.** Consider the system

$$\begin{aligned}\dot{x} &= y \\ \dot{y} &= x - x^3 - \gamma y, \quad \gamma \geq 0\end{aligned}$$

The equilibria of the system are:

$$(x^*, y^*) = (0, 0), (\pm 1, 0)$$

The Jacobian of the nonlinear dynamics is

$$\begin{bmatrix} \partial f_1 / \partial x & \partial f_1 / \partial y \\ \partial f_2 / \partial x & \partial f_2 / \partial y \end{bmatrix} = \begin{bmatrix} 0 & 1 \\ 1 - 3x^2 & -\gamma \end{bmatrix}$$

The eigenvalues associated with the equilibrium  $(0, 0)$  are  $\lambda_{1,2} = \frac{-\gamma \pm \sqrt{\gamma^2 + 4}}{2}$ , hence for  $\gamma \geq 0$  this equilibrium is unstable. The eigenvalues associated with the equilibrium  $(\pm 1, 0)$  are  $\lambda_{1,2} = \frac{-\gamma \pm \sqrt{\gamma^2 - 8}}{2}$ , hence for  $\gamma > 0$  these equilibria are asymptotically stable, while for  $\gamma = 0$  these equilibria are stable in the linear approximation.

As we can see, when  $\gamma = 0$  two of the equilibria become non-hyperbolic and the behaviour of the system close to them is different to that of the linearization. Later on in this course, we will consider what happens as parameters, such as  $\gamma$  in the example above, change: we will introduce the notion of *bifurcation* which describes how the behaviour close to non-hyperbolic solutions changes with parametric changes.

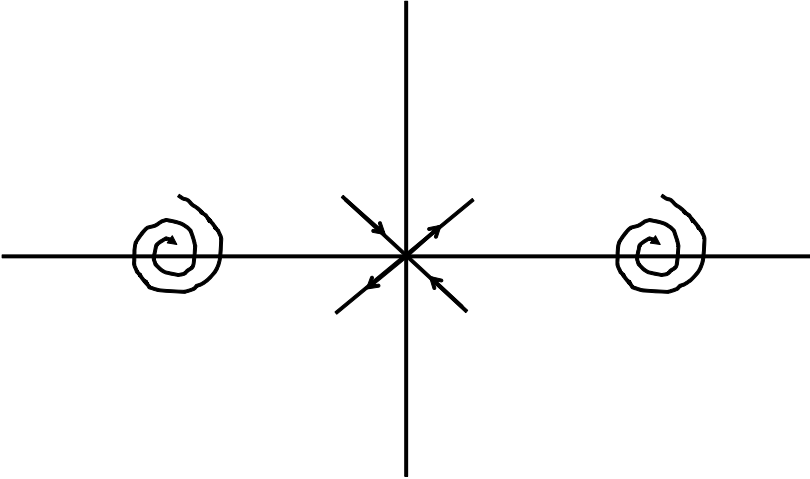

Figure 16: The phase plane of the system in Example 2.3.

### 3 Invariant manifolds

In this lecture we will consider further the phase-space properties of linear and nonlinear systems and concentrate on the case of non-hyperbolic equilibria.

#### 3.1 Linear Systems: Stable, Unstable and Centre Subspaces

Recall that the behaviour of solutions of a linear system

$$\dot{\mathbf{w}} = \mathbf{A}\mathbf{w} \quad (3.1)$$

where  $\mathbf{w} \in \mathbb{R}^n$  and  $\mathbf{A} \in \mathbb{R}^{n \times n}$  depends on the eigenvalues of  $\mathbf{A}$ . We will denote

$$\begin{aligned} \operatorname{Re} \lambda < 0, & \quad \lambda_1^S, \lambda_2^S, \dots, \lambda_s^S, \\ \operatorname{Re} \lambda > 0, & \quad \lambda_1^U, \lambda_2^U, \dots, \lambda_u^U, \\ \operatorname{Re} \lambda = 0, & \quad \lambda_1^C, \lambda_2^C, \dots, \lambda_c^C, \end{aligned}$$

with  $s + u + c = n$ . The eigenvectors corresponding to each eigenvalue will be denoted by  $\mathbf{u}_1^S, \dots, \mathbf{u}_s^S$  etc. Recall also that the solution to (3.1) from an initial condition of the form

$$\mathbf{w}(0) = c_1 \mathbf{u}_1 + \dots + c_n \mathbf{u}_n$$

is

$$\mathbf{w}(t) = c_1 e^{\lambda_1 t} \mathbf{u}_1 + \dots + c_n e^{\lambda_n t} \mathbf{u}_n$$

The solution of (3.1) can then be written as

$$\mathbf{w}(t) = \underbrace{\sum_{i=1}^s c_i^S \mathbf{w}_i^S(t)}_{\triangleq \mathbf{w}^S(t)} + \underbrace{\sum_{i=1}^u c_i^U \mathbf{w}_i^U(t)}_{\triangleq \mathbf{w}^U(t)} + \underbrace{\sum_{i=1}^c c_i^C \mathbf{w}_i^C(t)}_{\triangleq \mathbf{w}^C(t)}$$

where  $\mathbf{w}_1^S(t) = e^{\lambda_1^S t} \mathbf{u}_1^S$  etc. The subspace of solutions  $\mathbf{w}^S(t)$  is a linear combination of  $\mathbf{w}_i^S$  which span a subspace of the phase-space corresponding to  $\operatorname{Re} \lambda < 0$ ; we call this the *stable subspace*  $E^S$ . In a similar fashion, we can define  $E^U$  and  $E^C$ .

Consider now a change of coordinates in the original system, so that

$$\mathbf{w} = \mathbf{T}\mathbf{z}, \quad \mathbf{z} = \begin{bmatrix} \mathbf{z}_S \\ \mathbf{z}_U \\ \mathbf{z}_C \end{bmatrix}$$

Then we have that

$$\dot{\mathbf{z}} = \mathbf{T}^{-1}\dot{\mathbf{w}} = \mathbf{T}^{-1}\mathbf{A}\mathbf{w} = \mathbf{T}^{-1}\mathbf{A}\mathbf{T}\mathbf{z}$$

If we ensure that  $\mathbf{T}^{-1}\mathbf{A}\mathbf{T}$  is of the form

$$\mathbf{T}^{-1}\mathbf{A}\mathbf{T} = \begin{bmatrix} \mathbf{A}_S & 0 & 0 \\ 0 & \mathbf{A}_U & 0 \\ 0 & 0 & \mathbf{A}_C \end{bmatrix}$$

where  $\mathbf{A}_S$  has eigenvalues with negative real part,  $\mathbf{A}_U$  eigenvalues with positive real part and  $\mathbf{A}_C$  eigenvalues with zero real part, then we can write

$$\dot{\mathbf{z}}_S = \mathbf{A}_S\mathbf{z}_S$$

$$\dot{\mathbf{z}}_U = \mathbf{A}_U\mathbf{z}_U$$

$$\dot{\mathbf{z}}_C = \mathbf{A}_C\mathbf{z}_C$$

What the above says is that any solution that starts in  $E^S$ ,  $E^U$  or  $E^C$  at time  $t = 0$  will remain in  $E^S$ ,  $E^U$  or  $E^C$  respectively for all  $t \in \mathbb{R}$ . We say that these spaces are *invariant with respect to the flow*  $e^{t\mathbf{A}}$ . This means that the invariant subspaces divide the phase-space in smaller parts, each of which is invariant. It is also possible to consider the dynamics of the system restricted to each of these subspaces. The centre subspace is of particular importance but we will not dwell on it further here.

**Example 3.1.** Consider the system

$$\dot{\mathbf{x}} = \begin{bmatrix} -3 & 0 & 0 \\ 0 & 3 & -2 \\ 0 & 1 & 1 \end{bmatrix} \mathbf{x}$$

This system is block-diagonal and hence the eigenvalues are the eigenvalues of the blocks:  $\lambda_1 = -3$ ,  $\lambda_{2,3} = 2 \pm j$  with eigenvectors  $[1 \ 0 \ 0]^\top$ ,  $[0 \ 1 \pm j \ 1]^\top$ .

The solution (see Lecture 1) is

$$\mathbf{x}(t) = \begin{bmatrix} e^{-3t} & 0 & 0 \\ 0 & e^{2t}(\cos t + \sin t) & -2e^{2t} \sin t \\ 0 & e^{2t} \sin t & e^{2t}(\cos t - \sin t) \end{bmatrix} \mathbf{x}(0)$$

What does the phase-space look like? See Figure 17.

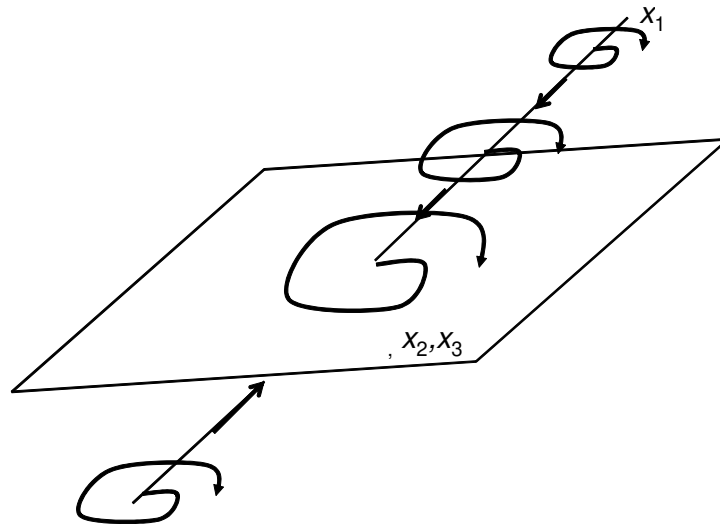

Figure 17: The phase space of the system in Example 3.1.

**Example 3.2.** Consider the system

$$\dot{\mathbf{x}} = \begin{bmatrix} \lambda & 1 & 0 \\ 0 & \lambda & 0 \\ 0 & 0 & \gamma \end{bmatrix} \mathbf{x}$$

with  $\lambda < 0$  and  $\gamma > 0$ . The eigenvalues of the matrix  $\mathbf{A}$  are  $\lambda$  (repeated) and  $\gamma$ . This is a degenerate case, i.e., there are only 2 eigenvectors, one corresponding to  $\gamma$  and one to  $\lambda$ . The unstable subspace is therefore the  $x_3$  axis and the  $x_1, x_2$  plane is the stable subspace. The phase portrait for this system is shown in Figure 18.

**Example 3.3.** Consider the system

$$\dot{\mathbf{x}} = \begin{bmatrix} 0 & -1 & 0 \\ 1 & 0 & 0 \\ 0 & 0 & 2 \end{bmatrix} \mathbf{x}$$

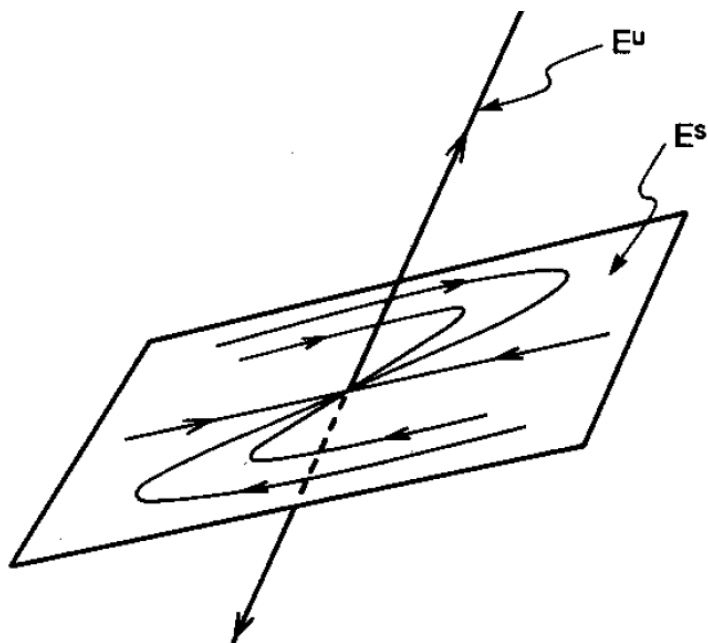

Figure 18: The phase space of the system in Example 3.2.

with eigenvalues  $\lambda_{1,2} = \pm j$  and eigenvectors  $[1 \ -j \ 0]^T$  and  $[1 \ j \ 0]^T$  respectively and  $\lambda_3 = 2$  with eigenvector  $[0 \ 0 \ 1]^T$ . The unstable subspace is therefore the  $x_3$  axis and the  $x_1, x_2$  plane is the centre subspace. The phase portrait for this system is shown in Figure 19 - note how solutions lie on the cylinders  $x_1^2 + x_2^2 = c^2$ .

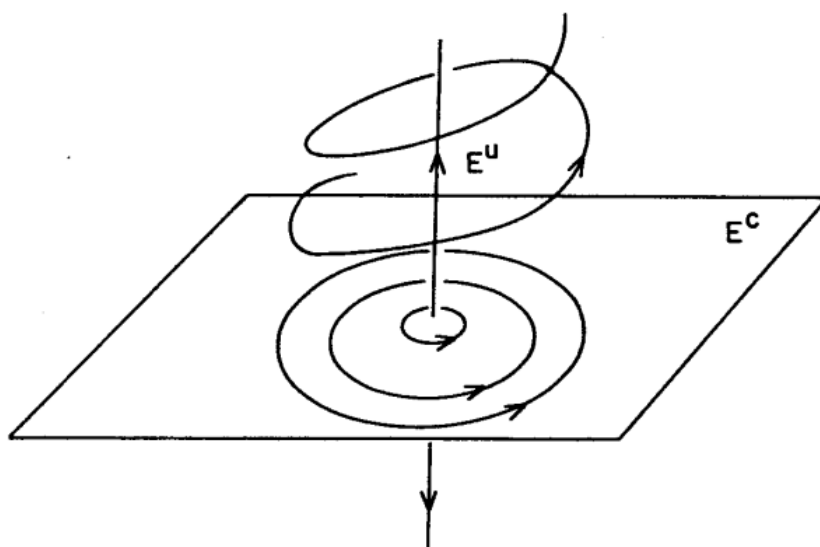

Figure 19: The phase space of the system in Example 3.3.

In the above examples we see that we can make the following predictions:

$$\lim_{t \rightarrow \infty} \mathbf{w}^S(t) = 0, \quad \lim_{t \rightarrow -\infty} \mathbf{w}^U(t) = 0$$

For the Centre subspace, no such limit can be written directly – in the above example the solutions in  $E^C$  are bounded, but this is not true in general. Consider, for example the simple case of

$$\mathbf{A} = \begin{bmatrix} 0 & 0 \\ 1 & 0 \end{bmatrix} \quad (3.2)$$

See Figure 20 for the phase plane of this system. It can be seen that solutions nearby the equilibrium can become unbounded.

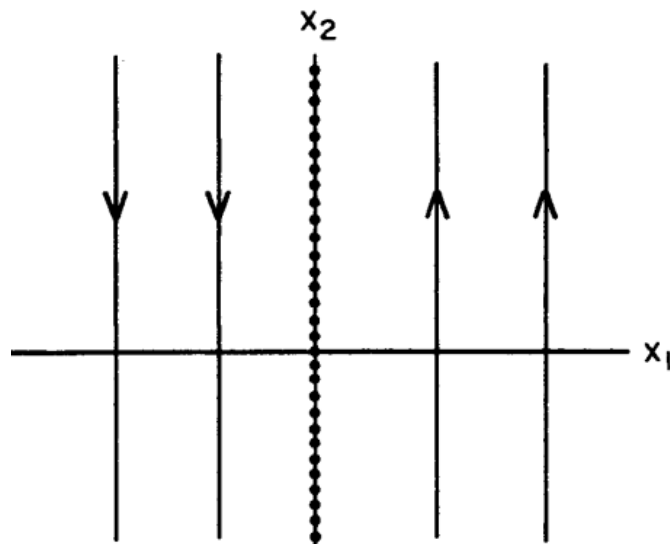

Figure 20: The phase plane of  $\mathbf{A}$  in Equation 3.2.

### 3.2 Nonlinear Systems: Local theory and Invariance

Let us now return to the nonlinear system

$$\dot{\mathbf{x}} = \mathbf{f}(\mathbf{x})$$

which can be linearized about an equilibrium of interest as we discussed in Lecture 2, to give

$$\dot{\mathbf{w}} = D\mathbf{f}(\mathbf{x}^*)\mathbf{w} + \mathcal{O}(\|\mathbf{w}\|^2)$$

where  $\mathbf{x} = \mathbf{x}^* + \mathbf{w}$ . The procedure of diagonalization that was discussed at the end of the previous section can still be performed but this will result in the following transformed system:

$$\begin{aligned}\dot{\mathbf{z}}_S &= \mathbf{A}_S \mathbf{z}_S + \mathbf{R}_S(\mathbf{z}) \\ \dot{\mathbf{z}}_U &= \mathbf{A}_U \mathbf{z}_U + \mathbf{R}_U(\mathbf{z}) \\ \dot{\mathbf{z}}_C &= \mathbf{A}_C \mathbf{z}_C + \mathbf{R}_C(\mathbf{z})\end{aligned}$$

The question is whether the remainder terms  $\mathbf{R}_S$ ,  $\mathbf{R}_U$  and  $\mathbf{R}_C$ , which are nonlinear functions of  $\mathbf{z}$  would affect the invariance of the stable, unstable and centre manifolds. A “Manifold” here means a ‘locally smooth surface’ in  $\mathbb{R}^n$ . Also, we would like to know whether topologically, the local behaviour of the equilibrium of the nonlinear system is the same as the one of the linear system.

The **Hartman-Grobman Theorem** is a central result in Dynamical Systems and states that in the case of hyperbolic equilibria, there exists a bi-continuous function  $H$  of a region containing the equilibrium (of the phase-space of the nonlinear system) to a region containing the origin (of the phase-space of the linearization) such that trajectories are mapped exactly, and parameterization of time is preserved.

Finding the transformation as well as what the invariant subspaces look like for nonlinear systems is beyond the scope of the course. Please see the reference books if this interests you.

**Example 3.4.** Figure 21 shows the two phase planes for the nonlinear system

$$\begin{aligned}\dot{x}_1 &= -x_1 \\ \dot{x}_2 &= x_2 + x_1^2\end{aligned}$$

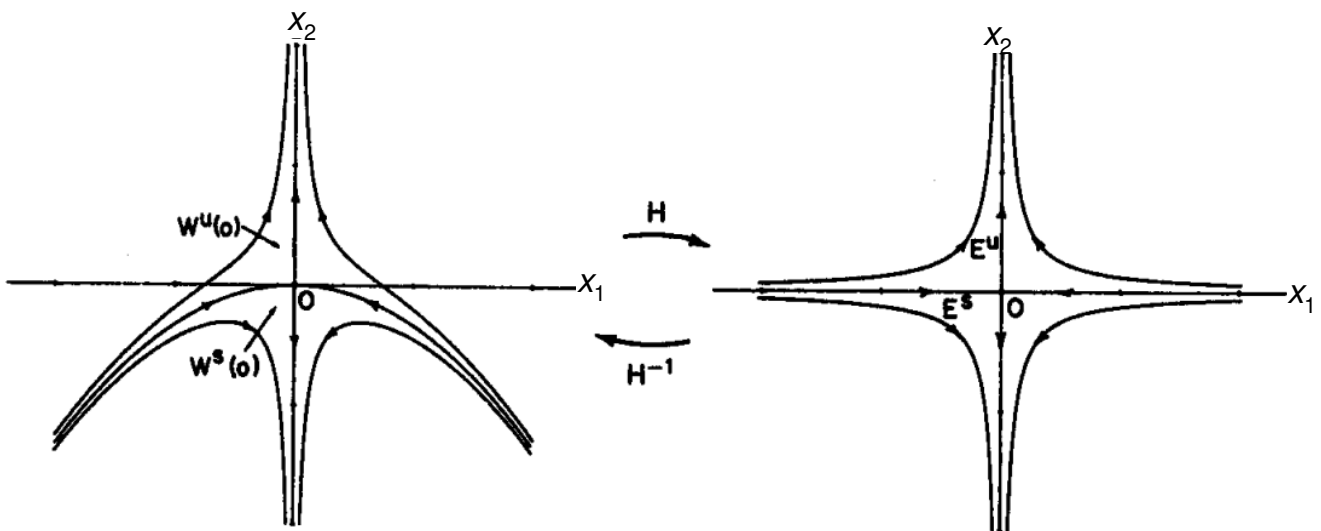

Figure 21: The phase plane of the nonlinear system in Example 3.4 (left) and its linearization about the zero equilibrium (right).

### 3.3 Non-hyperbolic equilibria

We now turn our attention to the case of non-hyperbolic equilibria and the various cases that may emerge. Recall that if the equilibrium is non-hyperbolic, the equilibrium of the original nonlinear system may or may not be a center. There are several ways to decide whether it is or not.

#### Transformation to polar coordinates

The first is to convert the dynamics in *polar coordinates*. Consider a 2-D autonomous system of the form

$$\begin{aligned}\dot{x}_1 &= f_1(x_1, x_2) \\ \dot{x}_2 &= f_2(x_1, x_2)\end{aligned}$$

and let  $(r, \theta)$  be a new coordinate system with  $x_1 = r \cos \theta$  and  $x_2 = r \sin \theta$ . Then the above system can be rewritten using the following transformations

$$\dot{r} = \frac{x_1 \dot{x}_1 + x_2 \dot{x}_2}{r}, \quad \dot{\theta} = \frac{x_1 \dot{x}_2 - x_2 \dot{x}_1}{r^2}$$

(See the Examples paper.) Once the system is transformed in these coordinates, it is easy to determine whether  $r$  (the 'radius') grows or shrinks, or stays constant.

**Example 3.5.** Consider the system

$$\begin{aligned}\dot{x} &= -y - xy \\ \dot{y} &= x + x^2\end{aligned}$$

For  $r > 0$  we have

$$\dot{r} = \frac{x\dot{x} + y\dot{y}}{r} = \frac{-xy - x^2y + xy + x^2y}{r} = 0$$

and

$$\dot{\theta} = \frac{x\dot{y} - y\dot{x}}{r^2} = \frac{x^2 + x^3 + y^2 + xy^2}{r^2} = 1 + x$$

Hence in a neighbourhood of the origin, the 0 equilibrium is a nonlinear centre.

## Symmetry

We say that a 2-dimensional nonlinear system  $\dot{\mathbf{x}} = \mathbf{f}(\mathbf{x})$  is symmetric with respect to the  $x_1$  axis, if it is invariant under the transformation  $(t, x_2) \rightarrow (-t, -x_2)$  and vice-versa.

If a system is symmetric with respect to one of the axes, and if the origin is a centre for the linearization, then the origin is a centre for the nonlinear system.

**Example 3.6.** Consider the system

$$\begin{aligned}\dot{x}_1 &= x_2 - x_2^3 \triangleq f(x_1, x_2) \\ \dot{x}_2 &= -x_1 - x_2^2 \triangleq g(x_1, x_2)\end{aligned}$$

This system has a linear centre at the origin and is symmetric with respect to the  $x_1$  axis. Note that

$$f(x_1, -x_2) = -f(x_1, x_2)$$

$$g(x_1, -x_2) = g(x_1, x_2)$$

and so

$$\begin{aligned}\frac{dx_1}{d(-t)} &= f(x_1, -x_2) \\ \frac{d(-x_2)}{d(-t)} &= g(x_1, -x_2)\end{aligned}$$

Hence the origin is a nonlinear centre.

### Conservative systems

If there exists an energy-like function  $V(\mathbf{x})$  which is 'preserved' along the trajectories of the system then the system is called *conservative*. The exact condition it needs to satisfy is for there to exist a non-constant function  $V : \mathbb{R}^n \rightarrow \mathbb{R}$  with  $\frac{dV(\mathbf{x})}{dt} = 0$ . If the system has an *isolated* equilibrium at  $\mathbf{x} = \mathbf{x}^*$  (i.e., there are no other equilibria in a neighbourhood around it) and one can construct such a  $V(\mathbf{x})$  with a local minimum or maximum at  $\mathbf{x}^*$  then there is a region around the equilibrium which contains a *closed orbit*.

Constructing a  $V(\mathbf{x})$  is sometimes easy, e.g., in the case of

$$\begin{aligned}\dot{x}_1 &= x_2 \\ \dot{x}_2 &= f(x_1)\end{aligned}$$

one can integrate the following expression

$$-f(x_1)\dot{x}_1 + x_2\dot{x}_2 = 0$$

See the examples paper for more details and an example.

Another case where constructing a  $V(\mathbf{x})$  is easy is for the type of system

$$\begin{aligned}\dot{x}_1 &= f(x_1)g_1(x_2) \\ \dot{x}_2 &= f(x_2)g_2(x_1)\end{aligned}$$

It is easy to show that

$$\frac{g_2(x_1)}{f(x_1)}\dot{x}_1 - \frac{g_1(x_2)}{f(x_2)}\dot{x}_2 = 0$$

which can be integrated to yield  $V(\mathbf{x})$ .

**Example 3.7.** Consider the system

$$\begin{aligned}\dot{x}_1 &= x_1 - x_1x_2 \\ \dot{x}_2 &= -x_2 + x_1x_2\end{aligned}$$

Linear analysis reveals that  $(0, 0)$  is a saddle point and  $(1, 1)$  is a linear centre. To show that  $(1, 1)$  is a nonlinear centre we construct a function  $V(\mathbf{x})$ , recognizing that

$$\begin{aligned}\dot{x}_1 &= x_1(1 - x_2) \\ \dot{x}_2 &= x_2(-1 + x_1)\end{aligned}$$

We have

$$\frac{-1 + x_1}{x_1}\dot{x}_1 - \frac{1 - x_2}{x_2}\dot{x}_2 = 0$$

which can be integrated to give

$$x_1 + x_2 - \ln(x_1x_2) = c$$

where  $c$  is a constant. It can be easily shown that  $(1, 1)$  is a local minimum of the function  $x_1 + x_2 - \ln(x_1x_2)$  and therefore  $(1, 1)$  is a nonlinear centre.

The function  $V(\mathbf{x})$  is very important in Dynamical Systems and will be the topic of discussion of the next lecture.

## 4 Lyapunov functions

Lyapunov functions and Lyapunov methods can be used to determine the stability of equilibria of dynamical systems even when linearization fails to conclude this; and provide a clearer picture about the far-from-equilibrium behaviour of the system, which is of interest in several cases.

The idea behind Lyapunov functions is the following. Suppose there is a region  $U$  around the equilibrium, whose boundary is such that the vector field always points inwards or is tangential to it. Then, obviously, trajectories cannot escape it. See Figure 22.

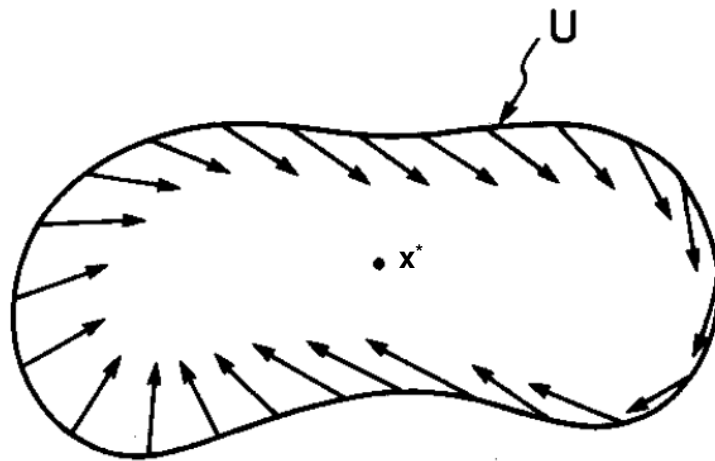

Figure 22: The Lyapunov function concept – the vector field at the boundary of  $U$ .

Suppose that once they enter this region  $U$ , there is another surface whose boundary has the same property, all the way down to the equilibrium – this is illustrated in Figure 23.

In two-dimensional systems, recall that the gradient of a function  $V$ ,  $\nabla V$  is a vector that is always perpendicular to level sets of  $V$  and points in the direction of increasing  $V$  – see Figure 24. So our requirement that the vector field either points inward or is tangent to the level sets is

$$\nabla V(\mathbf{x}) \cdot \mathbf{f}(\mathbf{x}) \leq 0$$

Note also that the left hand side is equal to  $\frac{dV}{dt}$ . We are now ready to formulate Lyapunov theory.

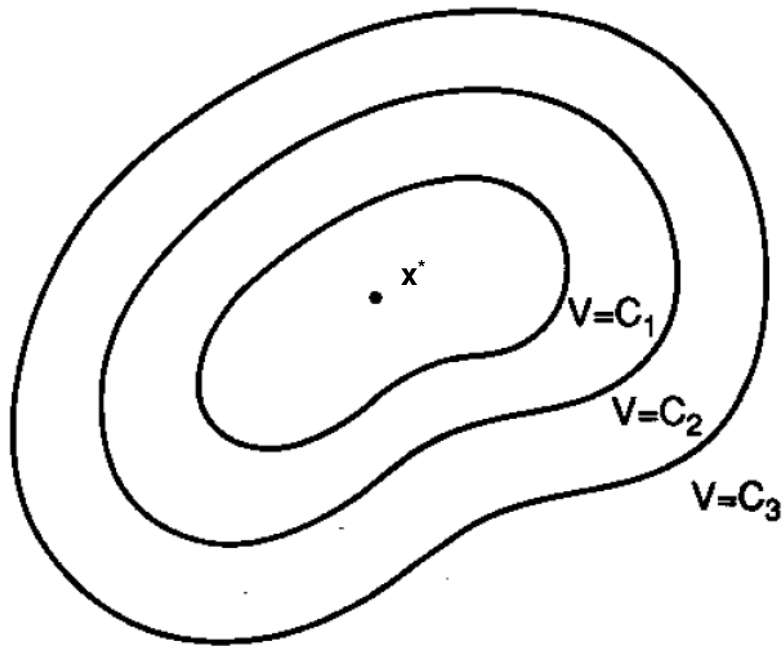

Figure 23: Level sets of the function  $V$ .

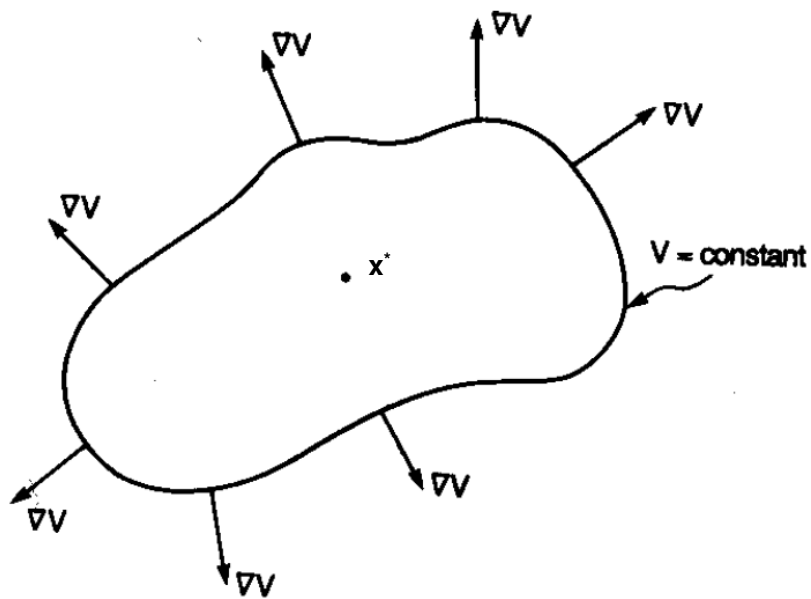

Figure 24:  $\nabla V$  and the region  $U$ .

#### 4.1 Lyapunov Functions

Here is Lyapunov's theorem - the concept is shown pictorially in Figure 25.

**Theorem 4.1.** Consider a nonlinear system of the form

$$\dot{\mathbf{x}} = \mathbf{f}(\mathbf{x})$$

and let  $\mathbf{x}^*$  be an equilibrium point (recall that this means that  $\mathbf{f}(\mathbf{x}^*) = \mathbf{0}$ ). Let  $V : D \rightarrow \mathbb{R}$  be a continuously differentiable function, defined on a neighbourhood  $D$  of  $\mathbf{x}^*$  such that

(i)  $V(\mathbf{x}^*) = 0$  and  $V(\mathbf{x}) > 0$  if  $\mathbf{x} \neq \mathbf{x}^*$ .

(ii)  $\dot{V}(\mathbf{x}) = \nabla V(\mathbf{x}) \cdot \mathbf{f}(\mathbf{x}) \leq 0$  in  $D - \{\mathbf{x}^*\}$ .

Then  $\mathbf{x}^*$  is stable. If moreover

(iii)  $\dot{V}(\mathbf{x}) < 0$  in  $D - \{\mathbf{x}^*\}$

then  $\mathbf{x}^*$  is asymptotically stable.

The function  $V(\mathbf{x})$  is called a *Lyapunov function*; if  $D = \mathbb{R}^n$  then  $\mathbf{x}^*$  is globally asymptotically stable, if  $V(\mathbf{x})$  is in addition radially unbounded.

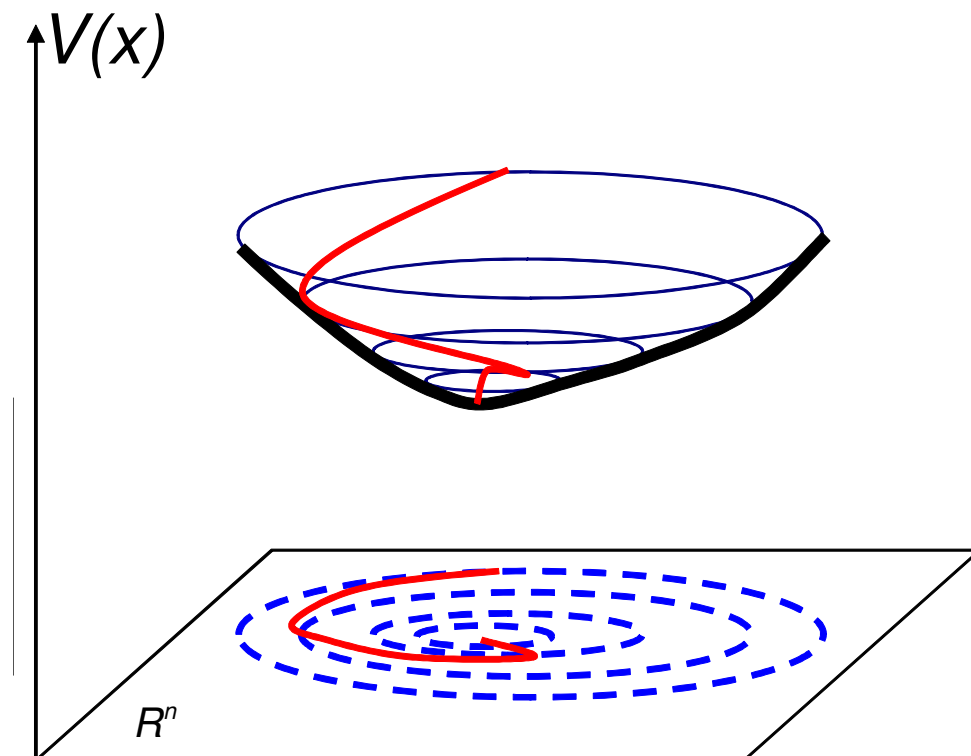

Figure 25: The main property of the Lyapunov function: the value of the function decreases along system trajectories; level curves provide regions that cannot be escaped.

**Example 4.1.** Consider the dynamical system

$$\begin{aligned}\dot{x} &= y \\ \dot{y} &= -x + \epsilon x^2 y\end{aligned}$$

Linearization around the equilibrium  $(0, 0)$  reveals a centre (a non-hyperbolic equilibrium) and hence we resort to Lyapunov theory to show stability.

Consider  $V(x, y) = \frac{1}{2}(x^2 + y^2)$ . Condition (i) in the theorem above is obviously satisfied, and

$$\dot{V} = x\dot{x} + y\dot{y} = xy + \epsilon x^2 y^2 - xy = \epsilon x^2 y^2$$

Therefore,  $(0, 0)$  is globally stable for  $\epsilon < 0$ . (In the next lecture we will discuss what tools will allow us to conclude global asymptotic stability in this case).

**Example 4.2.** Consider the system

$$\begin{aligned}\dot{x}_1 &= -2x_2 + x_2x_3 \\ \dot{x}_2 &= x_1 - x_1x_3 \\ \dot{x}_3 &= x_1x_2\end{aligned}$$

The origin is an equilibrium point for this system, which is a linear centre, i.e. non-hyperbolic. To find a Lyapunov function, consider a function of the form

$$V(\mathbf{x}) = \frac{1}{2} (c_1 x_1^2 + c_2 x_2^2 + c_3 x_3^2)$$

Computing  $\dot{V}$  we get

$$\begin{aligned}\dot{V} &= \frac{\partial V}{\partial x_1} \dot{x}_1 + \frac{\partial V}{\partial x_2} \dot{x}_2 + \frac{\partial V}{\partial x_3} \dot{x}_3 \\ &= (c_1 - c_2 + c_3)x_1x_2x_3 + (-2c_1 + c_2)x_1x_2\end{aligned}$$

and therefore if we choose  $c_2 = 2c_1 > 0$  and  $c_3 = c_1$  we have a Lyapunov function and the equilibrium is stable. We can actually go a step further and construct a *first integral* for the system, of the form

$$V(\mathbf{x}) = \frac{1}{2} (x_1^2 + 2x_2^2 + x_3^2)$$

for which  $\dot{V} = 0$ .

**Example 4.3.** Consider a simple model of a jet engine with a controller:

$$\begin{aligned}\dot{x}_1 &= -x_2 + 1.5x_1^2 - 0.5x_1^3 \\ \dot{x}_2 &= 3x_1 - x_2\end{aligned}$$

The origin is an equilibrium point for this system and is linearly stable. How does the system behave further away from the origin? A quadratic Lyapunov function does not exist for this system. A quartic function of the form

$$V(\mathbf{x}) = c_1x_1^2 + c_2x_2^2 + c_3x_1x_2 + c_4x_1^3 + \dots + c_kx_2^4$$

does however exist! This can be computed using recently developed tools – indeed, constructing Lyapunov functions was more of an art until about 10 years ago. Figure 26 shows the level curves of this Lyapunov function, which shows global stability of the equilibrium.

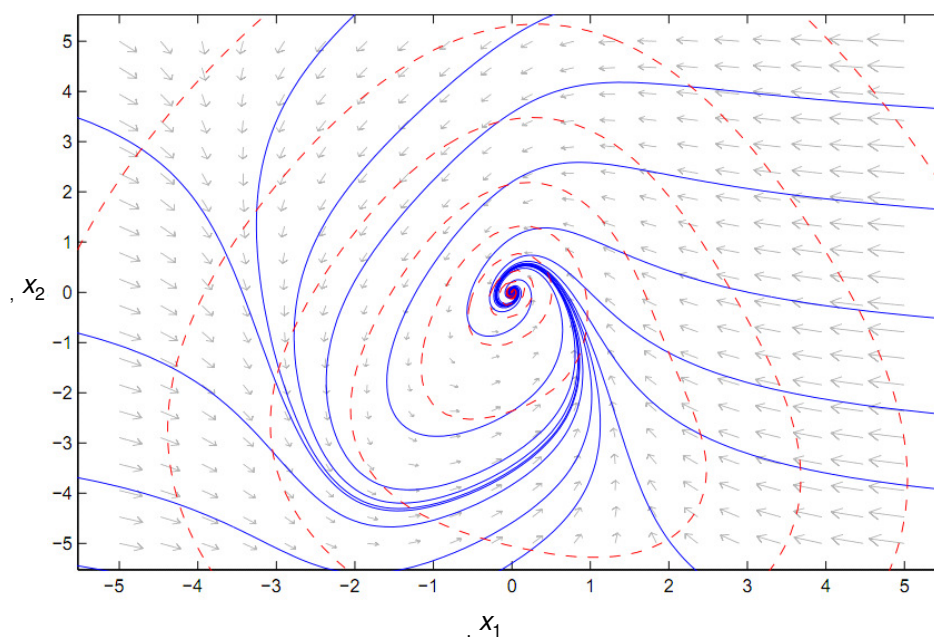

Figure 26: The level curves of the Lyapunov function which show global stability of the Jet engine model.

If the equilibrium of the original system  $\dot{\mathbf{x}} = \mathbf{f}(\mathbf{x})$  is not at the origin, but is at  $\mathbf{x}^*$ , a translation of coordinates  $\mathbf{z} = \mathbf{x} - \mathbf{x}^*$  will ensure that the equilibrium of the new system  $\dot{\mathbf{z}} = \mathbf{f}(\mathbf{z} + \mathbf{x}^*)$  has its equilibrium at  $\mathbf{z} = 0$ . Stability analysis of  $\mathbf{x}^*$  can then proceed by analyzing the stability of the zero equilibrium of the new system.

In the same way that Lyapunov theory can show stability of an equilibrium, it can be used to show instability: this is beyond the scope of this course.

## 4.2 Vector fields possessing an integral

Consider a nonlinear system of the form

$$\dot{\mathbf{x}} = \mathbf{f}(\mathbf{x})$$

We say that this vector field has an *integral*  $I(\mathbf{x})$  (a scalar-valued function) if

$$\frac{d}{dt}I(\mathbf{x}) = \frac{dI(\mathbf{x})}{d\mathbf{x}}\dot{\mathbf{x}} = \frac{dI(\mathbf{x})}{d\mathbf{x}}\mathbf{f}(\mathbf{x}) = 0$$

This means that  $I(\mathbf{x})$  is a *conserved quantity* and the dynamics of the system evolves on the level sets of  $I(\mathbf{x})$  - we have seen this in Example 4.2.

**Example 4.4.** Consider the pendulum equations:

$$\begin{aligned}\dot{q} &= p \\ \dot{p} &= -\frac{g}{\ell}\sin q\end{aligned}$$

This system has a conserved quantity, *total energy*, given by

$$E = \frac{1}{2}p^2 - \frac{g}{\ell}\cos q$$

Indeed,

$$\dot{E} = p\dot{p} + \frac{g}{\ell}\dot{q}\sin q = -p\frac{g}{\ell}\sin q + \frac{g}{\ell}p\sin q = 0.$$

**Example 4.5.** Consider the unforced duffing oscillator

$$\begin{aligned}\dot{x} &= y \\ \dot{y} &= x - x^3 - \delta y, \quad \delta \geq 0\end{aligned}$$

Let us consider the system for the case  $\delta = 0$ . In this case, the system has a first integral of the form

$$\frac{y^2}{2} - \frac{x^2}{2} + \frac{x^4}{4}.$$

Level curves of this function are trajectories of different 'energy' - if we draw them we can understand the structure of the dynamics far away from the equilibria.

Systems with vector fields possessing an integral are examples of Hamiltonian systems, which we study next.

### 4.3 Hamiltonian Systems

Systems of the form

$$\begin{aligned}\dot{\mathbf{p}} &= \mathbf{f}(\mathbf{p}, \mathbf{q}) \\ \dot{\mathbf{q}} &= \mathbf{g}(\mathbf{p}, \mathbf{q})\end{aligned}$$

where  $\mathbf{p}, \mathbf{q} \in \mathbb{R}^n$ , for which there exists a twice-differentiable function  $H(\mathbf{p}, \mathbf{q})$  defined on  $D \subseteq \mathbb{R}^{2n}$  such that

$$\begin{aligned}\mathbf{f}(\mathbf{p}, \mathbf{q}) &= -\frac{\partial H(\mathbf{p}, \mathbf{q})}{\partial \mathbf{q}} \\ \mathbf{g}(\mathbf{p}, \mathbf{q}) &= \frac{\partial H(\mathbf{p}, \mathbf{q})}{\partial \mathbf{p}}\end{aligned}$$

are called *Hamiltonian Systems* with  $n$  degrees of freedom. Note that all Hamiltonian systems are conservative. In the case of  $n = 1$ , the equilibria of the system are the critical points of  $H(p, q)$ .

Several conclusions can be drawn about the stability of those equilibria, depending on the properties of  $H$ . For example, if  $(p^*, q^*)$  is an equilibrium and  $H(p, q) > 0$  in a domain around the equilibrium, then this equilibrium is stable.

Newtonian systems of the form

$$\ddot{x} = f(x)$$

can be written as Hamiltonian systems by adding the 'potential' and 'kinetic' energy components. For example this system can be written as

$$\begin{aligned}\dot{x} &= y \\ \dot{y} &= f(x)\end{aligned}$$

in which case we can interpret  $(p, q) = (y, x)$ , and

$$H(p, q) = \frac{y^2}{2} - \int_{x_0}^x f(s) ds.$$

## 4.4 Gradient Systems

Suppose  $D \subseteq \mathbb{R}^n$  and suppose there exists a twice-differentiable function  $V(\mathbf{x})$  such that

$$\dot{x}_i = -\frac{\partial V}{\partial x_i}$$

Such a system is called a *gradient* system.

Equilibrium points of gradient systems correspond to critical points of  $V(\mathbf{x})$ ; at all other points, system trajectories are perpendicular to level sets of  $V$ . If a  $\mathbf{x}^*$  is a strict local minimum of  $V(\mathbf{x})$  then  $V(\mathbf{x}) - V(\mathbf{x}^*)$  is a Lyapunov function for  $\mathbf{x}^*$ , showing that it is asymptotically stable. If  $\mathbf{x}^*$  is a strict local maximum of  $V(\mathbf{x})$  then the equilibrium is unstable.

**Example 4.6.** The system

$$\begin{aligned}\dot{x} &= -4x(x-1)(x-0.5) \\ \dot{y} &= -2y\end{aligned}$$

is a gradient system with  $V(x, y) = x^2(x-1)^2 + y^2$ . Figure (27) shows the level sets of  $V(x, y)$  and the trajectories of the system.

## 4.5 A relationship between Gradient and Hamiltonian Systems

The system

$$\begin{aligned}\dot{x} &= f(x, y) \\ \dot{y} &= g(x, y)\end{aligned}\tag{4.1}$$

is orthogonal to

$$\begin{aligned}\dot{x} &= -g(x, y) \\ \dot{y} &= f(x, y)\end{aligned}\tag{4.2}$$

in the sense that trajectories of one are orthogonal to trajectories of the other. They have the same equilibria and in fact, centres of (4.1) correspond to nodes of (4.2), saddles of (4.1) correspond to saddles of (4.2), and foci of (4.1) correspond to foci of (4.2).

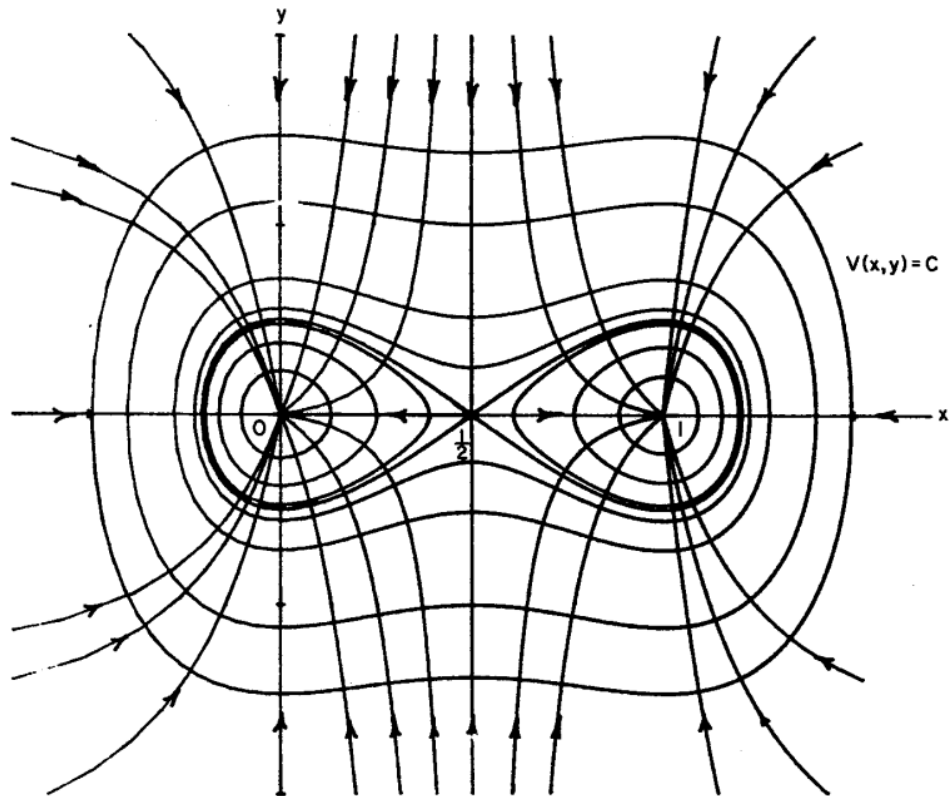

Figure 27: The level curves of  $V(x, y)$  in Example 4.6.

Moreover, if (4.1) is a Hamiltonian system with  $f = -\frac{\partial H}{\partial y}$  and  $g = \frac{\partial H}{\partial x}$  then (4.2) is a gradient system and vice versa.

## 5 Asymptotic Behaviour

So far we were interested in the local behaviour of nonlinear systems; we now turn our attention to their global behaviour.

Let us assume that

$$\dot{\mathbf{x}} = \mathbf{f}(\mathbf{x}) \quad (5.1)$$

has a solution  $\phi(t, \mathbf{x})$  on a domain  $D$ , through the point  $\mathbf{x}_0 = \mathbf{x}(0) \in D$ . This solution is a trajectory - this is essentially what we have been drawing on the phase plane in the previous lectures, i.e. the curve

$$\Gamma_{\mathbf{x}_0} = \{\mathbf{x} \in D, \text{ such that } \mathbf{x} = \phi(t, \mathbf{x}_0), t \in \mathbb{R}\}$$

What could ever be the long-term behaviour of these trajectories?

To understand this, we need to define two notions: the  $\alpha$  and  $\omega$  limit points of the trajectory  $\phi(t, \mathbf{x})$ :

**Definition 5.1.** A point  $\mathbf{p} \in D$  is called an  $\omega$  limit point of the trajectory  $\phi(t, \mathbf{x})$  if there exists a sequence of times,  $\{t_i\}$ ,  $t_i \rightarrow \infty$  such that

$$\lim_{i \rightarrow \infty} \phi(t_i, \mathbf{x}) \rightarrow \mathbf{p}$$

We denote this point  $\omega(\mathbf{x})$ .  $\alpha$  limit points are defined in a similar way, but now the sequence  $\{t_i\}$  is such that  $t_i \rightarrow -\infty$ .

The  $\alpha$  limit set of a trajectory is the set of all  $\alpha$  limit points. Similarly, we can define the  $\omega$  limit set.

**Example 5.1.** Any equilibrium point  $\mathbf{x}^*$  is its own  $\alpha$  and  $\omega$  limit point. If a trajectory  $\phi(t, \mathbf{x})$  has a unique  $\omega$  limit point  $\mathbf{x}^*$ , then  $\mathbf{x}^*$  is an equilibrium point.

**Example 5.2.** Consider a saddle point equilibrium. The equilibrium is an  $\omega$  limit point for any point on the stable manifold and an  $\alpha$  limit point for any point on the unstable manifold. In this example, it is obvious that no time sequence  $\{t_i\}$  needs to be taken.

The  $\omega$  and  $\alpha$  limit sets are not restricted to equilibria. If a point  $\mathbf{p}$  is in the  $\omega$  limit set of a trajectory and  $\mathbf{p} \neq \mathbf{0}$ , then this trajectory is a *closed orbit*.

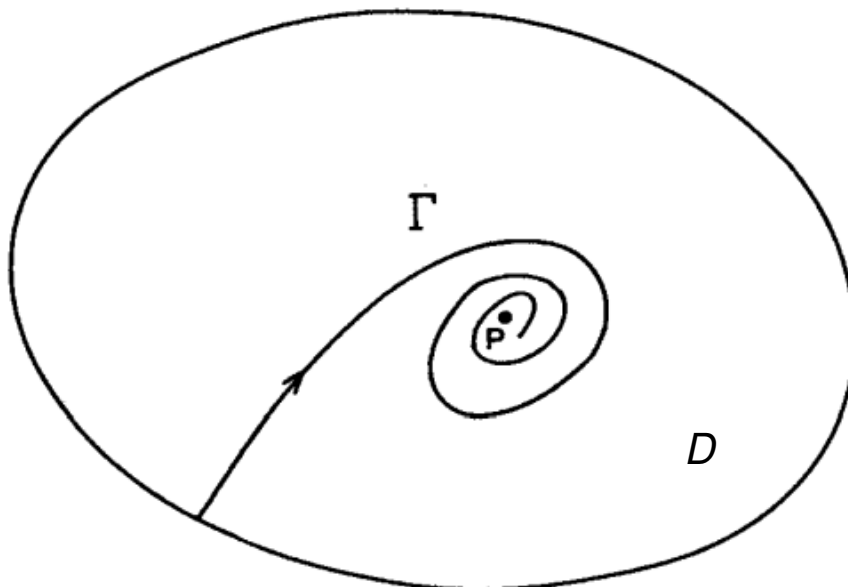

Figure 28: A trajectory which approaches an  $\omega$  limit point. Here a time sequence is not important.

We will consider limit orbits in the next lecture - the time-sequence is now important when defining  $\omega$  and  $\alpha$  limit points.

**Example 5.3.** Consider a globally attracting closed orbit; trajectories not starting on it approach it, but time sequences are important as without them we cannot have a sequence of points that tend to a limit point  $\mathbf{p}$  on the orbit. Note that in this case,  $\lim_{t \rightarrow \infty} \phi(t, \mathbf{x}) \neq \mathbf{p}$ . The limit cycle is the  $\omega$  limit set of  $\mathbf{p}$ . If the closed orbit was unstable, we could similarly define the  $\alpha$  limit set.

If a region  $M$  is positively invariant and closed and bounded, then the  $\omega$  limit set of any point  $\mathbf{x} \in M$  is non-empty (trajectories need to go somewhere!). Also,  $\omega(\mathbf{x})$  is invariant itself.

We now discuss notions of stability of attracting sets and ‘trapping’ regions.

**Definition 5.2.** An invariant set  $A \subset D$  is *attracting* if there is some neighbourhood  $U$  of  $A$  which is positively invariant and all trajectories starting in  $U$  tend to  $A$  as  $t \rightarrow \infty$ .

**Example 5.4.** A stable node or focus is the  $\omega$  limit set of any trajectory that

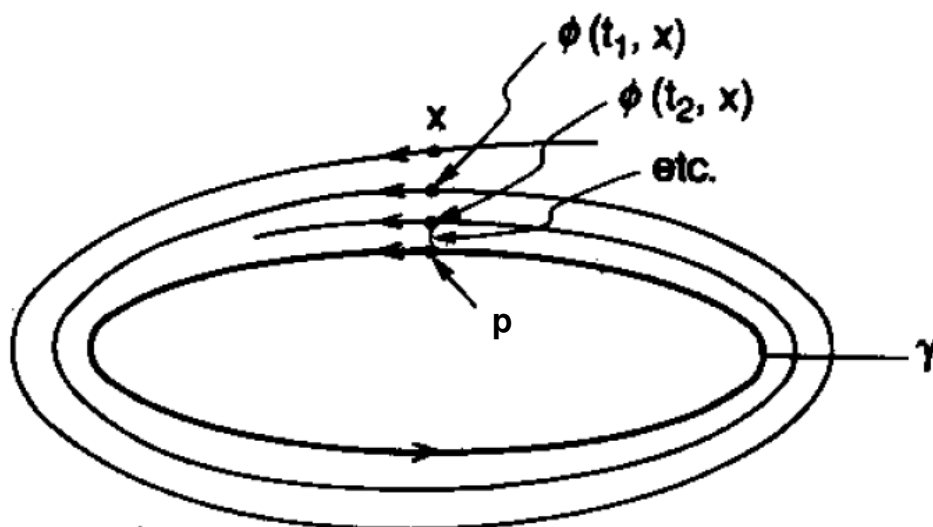

Figure 29: A stable closed orbit and the need for time sequences when defining the limit set.

starts in a neighbourhood around that equilibrium, i.e., that equilibrium is an attractor of the system (5.1). A saddle point, however, is not an attractor.

**Example 5.5.** Consider the system

$$\begin{aligned}\dot{x} &= -y + x(1 - x^2 - y^2) \\ \dot{y} &= x + y(1 - x^2 - y^2)\end{aligned}$$

Changing to polar coordinates, we have

$$\begin{aligned}\dot{r} &= r(1 - r^2) \\ \dot{\theta} &= 1.\end{aligned}$$

The origin is an equilibrium point of the system, which is actually unstable. Moreover,  $\dot{r} < 0$  if  $r > 1$ ;  $\dot{r} > 0$  if  $r < 1$  and  $\dot{r} = 0$  for  $r = 1$ , i.e. the unit circle will be a trajectory from  $(r, \theta) = (1, 0)$ , which is called a limit cycle. This trajectory is actually stable and is an attractor – it is the  $\omega$ -limit set of any point in  $\mathbb{R}^2$  apart from the origin. See Figure 30.

In the above example, the set  $U$  is essentially the whole of  $\mathbb{R}^2$  minus the zero equilibrium. The set  $U$  is called a *trapping region*: constructing such regions can be done using Lyapunov functions.

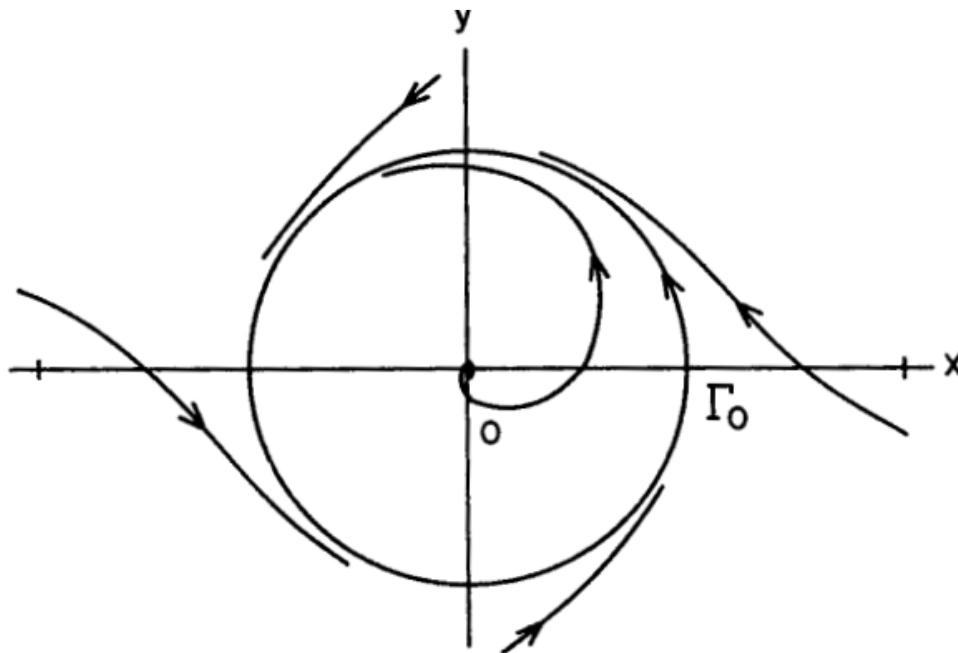

Figure 30: A stable limit cycle, which is an attractor of the system in Example 5.5.

## 5.1 LaSalle's invariance principle

Indeed, finding a Lyapunov function is equivalent to finding a trapping region: a region is trapping if along its boundary the vector field is pointing inwards or is tangent to it.

**Definition 5.3.** The *domain* or *basin* of attraction of an attracting set  $A$  is the union of all trajectories forming a trapping region of  $A$ .

**Example 5.6.** Consider, for example, the duffing oscillator. The basins of attraction of the two stable equilibria are essentially defined by the stable manifold of the saddle point at the origin.

We are now ready to discuss *LaSalle's invariance principle*.

Let  $\dot{\mathbf{x}} = \mathbf{f}(\mathbf{x})$  with  $\mathbf{x} \in \mathbb{R}^n$  and suppose  $D \subset \mathbb{R}^n$  is a positively invariant set. Suppose the boundary of  $D$  is differentiable and  $D$  has non-empty interior. This means that  $D$  is a trapping region.

Suppose now there exists a  $V(\mathbf{x})$  which satisfies  $\dot{V} \leq 0$  on  $D$  and consider the

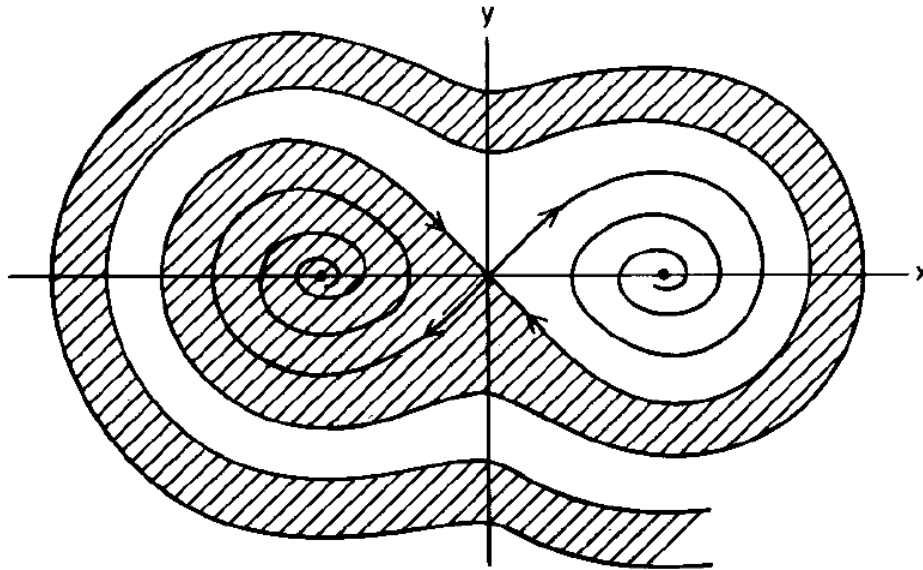

Figure 31: The domain of attraction of an equilibrium point of the Duffing oscillator.

following two sets:

$$E = \{\mathbf{x} \in D \text{ such that } \dot{V}(\mathbf{x}) = 0\}$$

and

$$M = \{\text{the union of all trajectories in } E \text{ that are positively invariant}\}$$

LaSalle's invariance principle then states that for all  $\mathbf{x} \in D$ , all trajectories starting at  $\mathbf{x}$  tend to  $M$  as  $t \rightarrow \infty$ .

LaSalle's invariance principle assumes the existence of a positively invariant set  $D$ . At this point, note that  $V(\mathbf{x})$  is not required to be positive definite! If  $V(\mathbf{x})$  is positive definite, then this (Lyapunov) function can provide  $D$  (level sets of  $V(\mathbf{x})$  will count towards that). However some times  $D$  is defined by constructing a trapping region directly – see the Examples paper.

**Example 5.7.** Consider for example the Duffing equation

$$\begin{aligned} \dot{x} &= y \\ \dot{y} &= x - x^3 - \gamma y, \quad \gamma > 0. \end{aligned}$$

and the following function

$$V(x, y) = \frac{y^2}{2} - \frac{x^2}{2} + \frac{x^4}{4}$$

which satisfies

$$\dot{V} = -\gamma y^2.$$

The set  $E$  consists of all points with  $y = 0$ , but only the points  $x = 0$ ,  $x = 1$  and  $x = -1$  are invariant. The level set  $V = c$  with  $c$  large is the boundary of a positively invariant region and that region contains these three points. Therefore, using LaSalle, all trajectories converge to one of these three equilibria. See Figure 32.

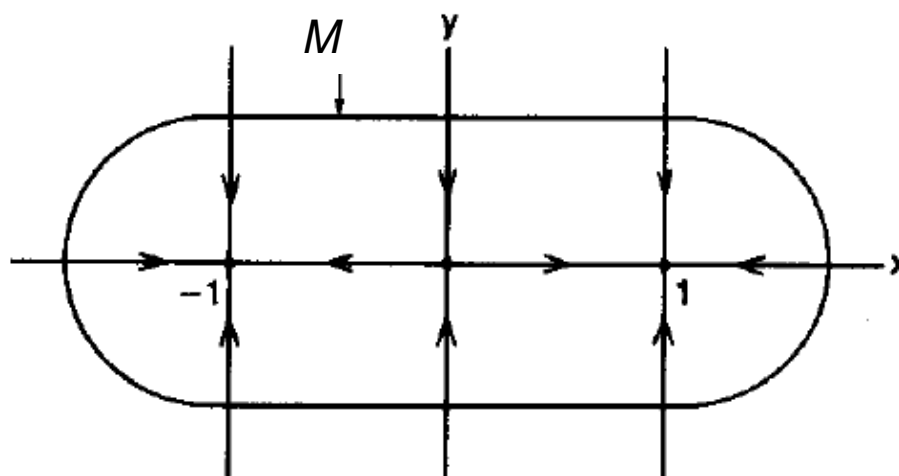

Figure 32: The asymptotic stability of the  $(\pm 1, 0)$  equilibria of the Duffing oscillator.

## 5.2 The Poincaré Bendixson Theorem

Beyond limit cycles, there are several other ‘exotic’ attractors in dynamical systems, that we will consider in Lecture 8. The question we now consider is what kind of attractors we expect to have on the *phase plane*, i.e. in  $\mathbb{R}^2$ .

The Poincaré Bendixson theorem considers two-dimensional vector fields and allows us to determine what the asymptotic behaviour of systems on the plane is, i.e., what attractors there can be on the plane. We have already seen limit cycles and periodic orbits, and we will study them in more detail in the next lecture, but what else can there be? Let’s first consider an example.

**Example 5.8.** The Hamiltonian system

$$\begin{aligned}\dot{x} &= y \\ \dot{y} &= x + x^2\end{aligned}$$

has a Hamiltonian

$$H(x, y) = \frac{y^2}{2} - \frac{x^2}{2} - \frac{x^3}{3}$$

and therefore the solution curves are defined by

$$y^2 - x^2 - \frac{2}{3}x^3 = c.$$

As we discussed in the previous lecture, these solution curves are trajectories of the system, and therefore we can plot the phase portrait of the system easily. In particular, the curve

$$y^2 = x^2 + 2x^3/3$$

goes through the origin and the point  $(-1.5, 0)$ ; it corresponds to a trajectory with the (saddle point) origin as its  $\alpha$  and  $\omega$  limit sets. Such a trajectory, which starts from the unstable manifold of the saddle and ends on the stable manifold of the saddle is called a *homoclinic* connection or orbit. This ‘cycle’ is called a *separatrix cycle* - see Figure 33.

Homoclinic orbits are not the only orbits of this type we have seen in this lecture course; *heteroclinic* connections can be seen in Figure 5 in Lecture 1 – there, a heteroclinic connection links two unstable equilibria (corresponding to the upward equilibrium). Also, the system

$$\begin{aligned}\dot{x} &= -2y \\ \dot{y} &= 4x(x-1)(x-0.5)\end{aligned}$$

which is orthogonal to the gradient system we discussed in Example 4.6, is Hamiltonian and the level curves shown on Figure 27 are trajectories of this system - the ‘bowtie’ homoclinic orbits around the point  $(0.5, 0)$  form a ‘compound separatrix cycle’. There are other compound separatrix cycles that one can have on the plane – see Figure 34. Note that all of them consist of a number of compatibly oriented separatrix cycles, each of which is a union of a finite number of critical points and compatibly oriented separatrices.

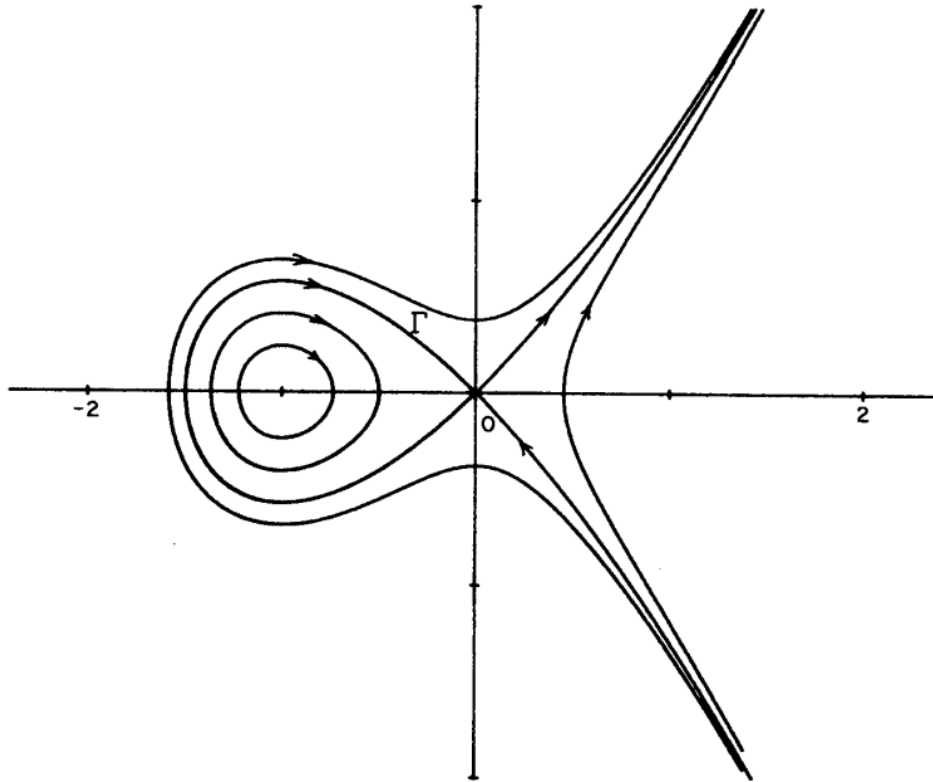

Figure 33: A homoclinic connection.

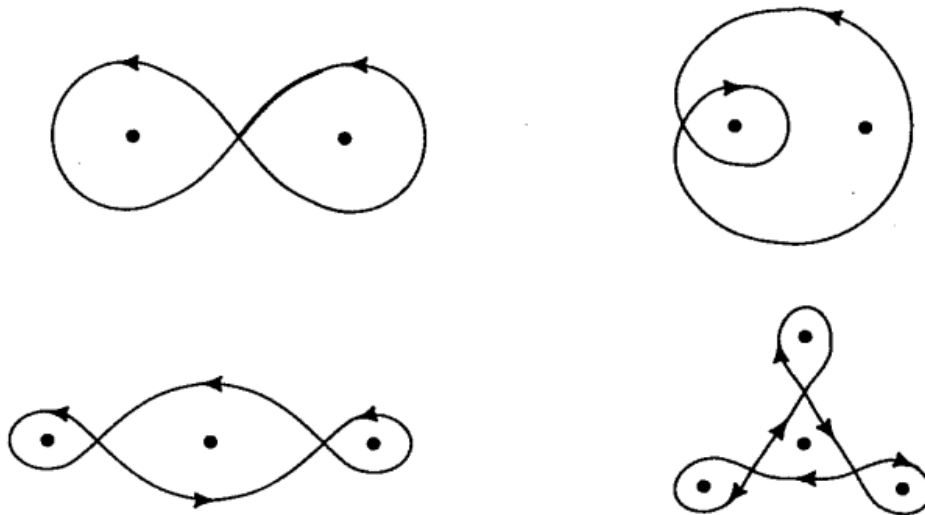

Figure 34: Various compound separatrix cycles.

Is this everything that can happen on the phase-plane of a nonlinear system? The **Poincaré Bendixson Theorem** is a fundamental result in Dynamical Systems, and states that the  $\alpha$  and  $\omega$  limit sets of any trajectory of a dynamical

system on the plane is either a critical point, a cycle, or a compound separatrix cycle.

The Poincaré-Bendixson theorem is as follows:

**Theorem 5.4.** *Let  $\dot{\mathbf{x}} = \mathbf{f}(\mathbf{x})$ ,  $\mathbf{x} \in \mathbb{R}^2$ , and assume  $\mathbf{f}$  is continuously differentiable. Let  $M$  be a positively invariant compact subset of  $\mathbb{R}^2$  containing only a finite number of equilibria. Let  $\mathbf{x} \in M$  and consider  $\omega(\mathbf{x})$ . Then one of the following possibilities holds:*

- (i)  $\omega(\mathbf{x})$  is an equilibrium;
- (ii)  $\omega(\mathbf{x})$  is a closed orbit;
- (iii)  $\omega(\mathbf{x})$  consists of a finite number of equilibria  $\mathbf{x}_1^*, \dots, \mathbf{x}_n^*$  and orbits  $\gamma$  with  $\alpha(\gamma) = \mathbf{x}_i^*$  and  $\omega(\gamma) = \mathbf{x}_j^*$ .

This is a deep theorem and there are several (not so obvious) conclusions from it. For example, if inside  $M$  there are only stable equilibria, then there can only be one. If there are no equilibria, then there is a closed orbit in it.

Let's see how the Poincaré-Bendixson is used in practice.

**Example 5.9.** Consider, again, the unforced Duffing oscillator:

$$\begin{aligned}\dot{x} &= y \\ \dot{y} &= x - x^3 - \gamma y, \quad \gamma > 0.\end{aligned}$$

The level curves of the function  $V(x, y) = 2y^2 - 2x^2 + x^4$  provide positively invariant regions for the stable equilibria. Using Poincaré Bendixson, the unstable manifold of the saddle at the origin must fall into the sinks. The two cases  $0 \leq \delta \leq \sqrt{8}$  and  $\delta > \sqrt{8}$  are shown in Figures 35 and 36 below.

**Example 5.10.** Consider the system

$$\begin{aligned}\dot{x}_1 &= x_1 + x_2 - x_1(x_1^2 + x_2^2) \\ \dot{x}_2 &= -x_1 + x_2 - x_2(x_1^2 + x_2^2)\end{aligned}$$

Does this system have a limit cycle? Linearizing about the origin, we obtain

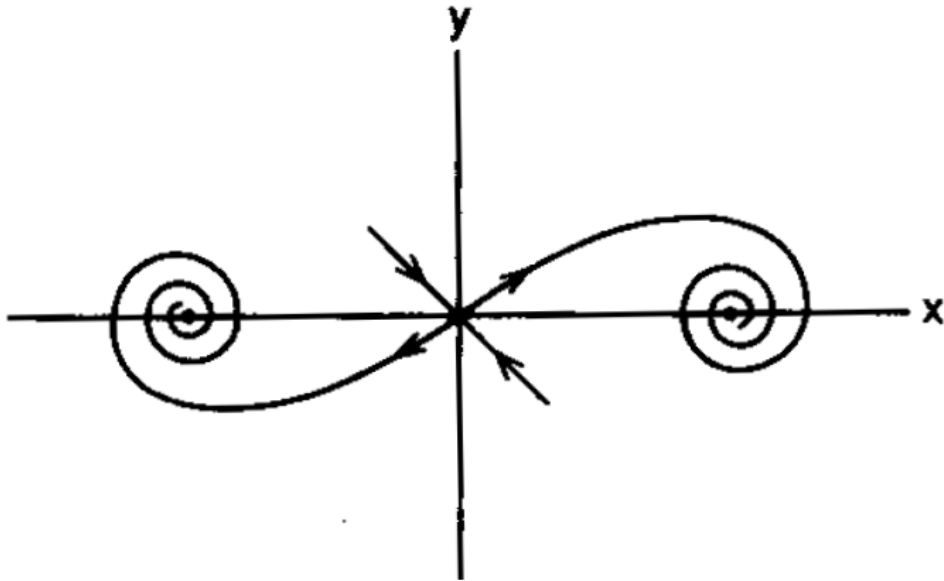

Figure 35: The Duffing oscillator for  $0 \leq \delta \leq \sqrt{8}$ .

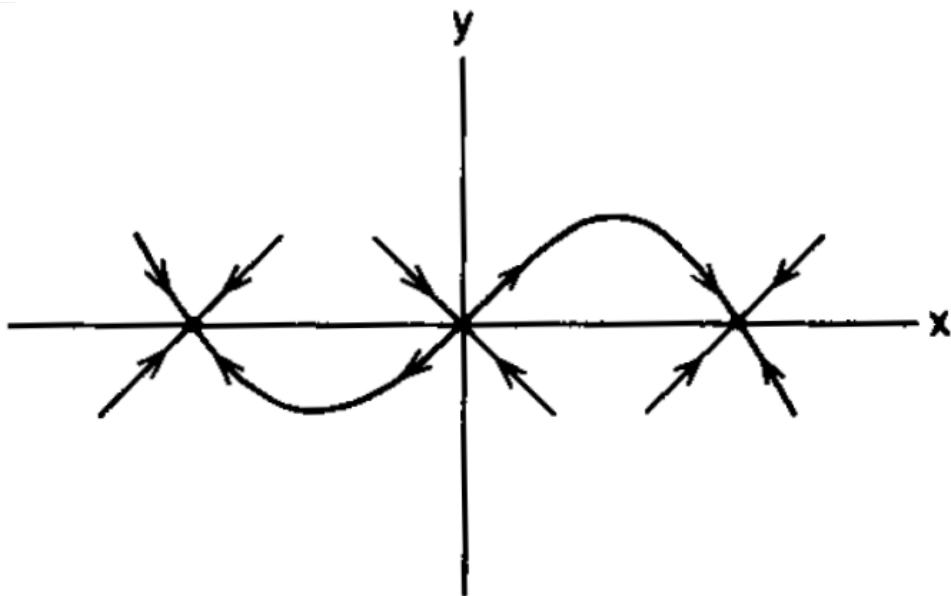

Figure 36: The Duffing oscillator for  $\delta > \sqrt{8}$ .

the Jacobian

$$J = \begin{bmatrix} 1 & 1 \\ -1 & 1 \end{bmatrix}$$

which has eigenvalues at  $1 \pm j$ ; hence the origin is an unstable spiral.

If we consider the region defined by

$$V(x_1, x_2) = \frac{x_1^2}{2} + \frac{x_2^2}{2} = c,$$

where  $c$  is large, then

$$\dot{V}(x_1, x_2) = x_1\dot{x}_1 + x_2\dot{x}_2 = (x_1^2 + x_2^2) - (x_1^2 + x_2^2)(x_1^2 + x_2^2) = 2c - 4c^2 < 0$$

defines an invariant region. As there is only one unstable equilibrium point inside the region, by Poincaré Bendixson the region must contain a stable limit cycle.

## 6 Limit Cycles and Index Theory

In this lecture, we consider periodic solutions of continuous-time systems. In particular, we are interested in *limit cycles* - we have already discussed periodic orbits and separatix cycles in the previous lecture. In essence, a *cycle* is a closed solution curve that is not an equilibrium solution of

$$\dot{\mathbf{x}} = \mathbf{f}(\mathbf{x}). \quad (6.1)$$

**Definition 6.1.** A solution of  $\dot{\mathbf{x}} = \mathbf{f}(\mathbf{x})$  through  $\mathbf{x}_0$  is said to be periodic if there exists a  $T > 0$  such that  $\phi(t; \mathbf{x}_0) = \phi(t + T; \mathbf{x}_0)$  for all  $t \in \mathbb{R}$ . The minimum such  $T$  is called a *period* of the periodic orbit.

The question of stability of periodic orbits will be discussed at the end of this lecture. For now, let's concentrate on ways to show existence (or non-existence) of periodic orbits.

### 6.1 Non-existence of Periodic Orbits for 2-D systems

Consider the 2-D system

$$\dot{x} = f(x, y) \quad (6.2)$$

$$\dot{y} = g(x, y) \quad (6.3)$$

with  $f$  and  $g$  continuously differentiable. The following is an important result towards establishing existence of periodic solutions:

**Theorem 6.2. (Bendixson)** *If  $\frac{\partial f}{\partial x} + \frac{\partial g}{\partial y}$  is not identically 0 and does not change sign on a region  $D$  of the phase-plane, then (6.2-6.3) has no closed orbits in this region.*

The proof of this theorem proceeds by contradiction; if there existed such a closed orbit, then, since

$$\frac{dy}{dx} = \frac{dy/dt}{dx/dt} = \frac{g(x, y)}{f(x, y)}$$

we have that

$$\oint_{\Gamma} f(x, y)dy - g(x, y)dx = 0$$

over a closed orbit  $\Gamma$  in  $D$ . Using Stoke's theorem in two dimensions (also called Green's Theorem), we obtain

$$\int_S \left( \frac{\partial f}{\partial x} + \frac{\partial g}{\partial y} \right) dx dy = 0$$

where  $S$  is a 'capping surface' in 2-D, i.e., the 'inside' of  $\Gamma$ . Obviously, if  $\left( \frac{\partial f}{\partial x} + \frac{\partial g}{\partial y} \right) \neq 0$  and does not change sign, there cannot be any closed orbits in  $D$ .

Dulac generalized Bendixson's criterion into the following theorem:

**Theorem 6.3. (Dulac)** *Let  $B(x, y)$  be a continuously differentiable function, defined on a region  $D \subset \mathbb{R}^2$ . If  $\frac{\partial Bf}{\partial x} + \frac{\partial Bg}{\partial y}$  is not identically 0 and does not change sign on a region  $D$  of the phase-plane, then (6.2-6.3) has no closed orbits in this region.*

**Example 6.1.** Consider

$$\begin{aligned} \dot{x} &= y \triangleq f(x, y) \\ \dot{y} &= x - x^3 - \delta y \triangleq g(x, y), \delta \geq 0 \end{aligned}$$

It is easy to see that

$$\frac{\partial f}{\partial x} + \frac{\partial g}{\partial y} = -\delta$$

and therefore for  $\delta > 0$  there are no closed orbits. But what happens for  $\delta = 0$ ? In that case, the system is Hamiltonian and the behaviour of the trajectories can be studied directly.

**Example 6.2.** Consider the following modification to the previous example:

$$\begin{aligned} \dot{x} &= y \triangleq f(x, y) \\ \dot{y} &= x - x^3 - \delta y + x^2 y \triangleq g(x, y), \quad \delta \geq 0 \end{aligned}$$

A simple analysis reveals that  $(0, 0)$  is a saddle and  $(\pm 1, 0)$  are sinks for  $\delta > 1$  and sources for  $0 \leq \delta < 1$ . It is easy to see that

$$\frac{\partial f}{\partial x} + \frac{\partial g}{\partial y} = -\delta + x^2$$

which vanishes when  $x = \pm\sqrt{\delta}$ . Obviously, there can be no closed orbits in the regions of the phase space corresponding to  $x < -\sqrt{\delta}$ ,  $-\sqrt{\delta} < x < \sqrt{\delta}$  and

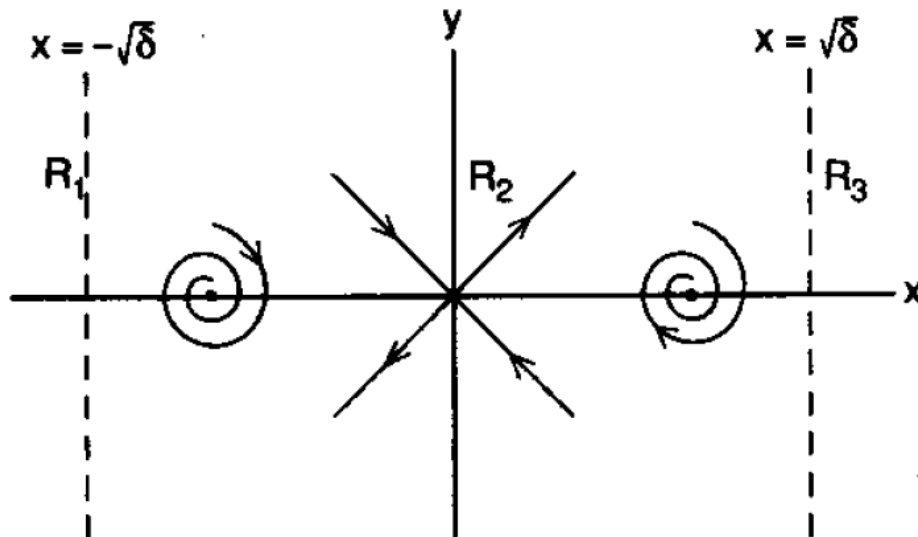

Figure 37: Regions within which no limit cycles exist, for  $\delta > 1$ .

$x > \sqrt{\delta}$  – see Figure 37. There may however exist orbits that overlap these regions (see Figure 38) – how can we decide? This can be studied further using *index theory* below.

## 6.2 Gradient Systems

A *gradient system* is a system of the form  $\dot{\mathbf{x}} = -\nabla V$  with  $\mathbf{x}(t) \in \mathbb{R}^n$  and  $V : \mathbb{R}^n \rightarrow \mathbb{R}$  – we have studied these systems in Lecture 4. If a system is gradient, then it has no closed orbits. This is easy to see, since

$$\frac{dV}{dt} = \frac{\partial V}{\partial \mathbf{x}} \frac{d\mathbf{x}}{dt} = \nabla V \cdot \dot{\mathbf{x}} = -\|\nabla V\|^2 = -\|\dot{\mathbf{x}}\|^2$$

Integrating over a time interval  $[0, T]$ ,

$$V(x(T)) - V(x(0)) = - \int_0^T \|\dot{\mathbf{x}}\|^2 dt$$

If a closed orbit existed, then  $\mathbf{x}(T) = \mathbf{x}(0)$  and hence the left hand side is zero; this means that  $\dot{\mathbf{x}} = 0$  for the whole time interval  $[0, T]$ , so  $\mathbf{x}(0)$  is a fixed point, not an orbit.

## 6.3 Index Theory

Index theory is a very useful method for deciding far-from-equilibrium behaviour of a system and is particularly useful for two-dimensional systems.

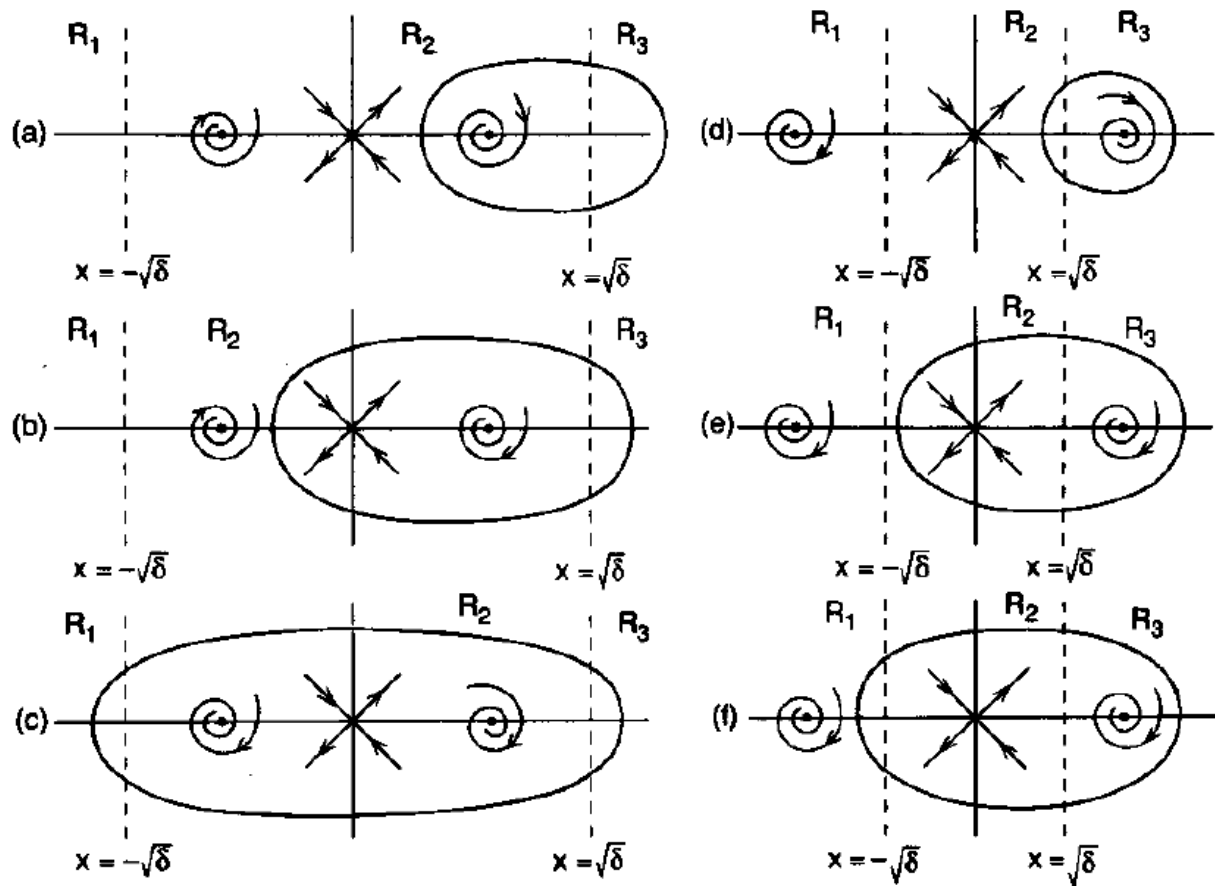

Figure 38: Regions within which limit cycles may exist.

It makes use of the fact that a system of the form

$$\dot{x}_1 = f(x_1, x_2)$$

$$\dot{x}_2 = g(x_1, x_2)$$

is such that the vector field  $\frac{dx_2}{dx_1} = \frac{g(x_1, x_2)}{f(x_1, x_2)}$  makes an angle

$$\varphi(x_1, x_2) = \arctan \left( \frac{g(x_1, x_2)}{f(x_1, x_2)} \right)$$

to the  $x_1$  axis. Given this angle and a simple closed curve  $\Gamma$  in  $\mathbb{R}^2$ , the *index* of  $\Gamma$ ,  $I(\Gamma)$  is defined by

$$I(\Gamma) = \oint_{\Gamma} \frac{d\varphi(x_1, x_2)}{2\pi}$$

See Figure 39.

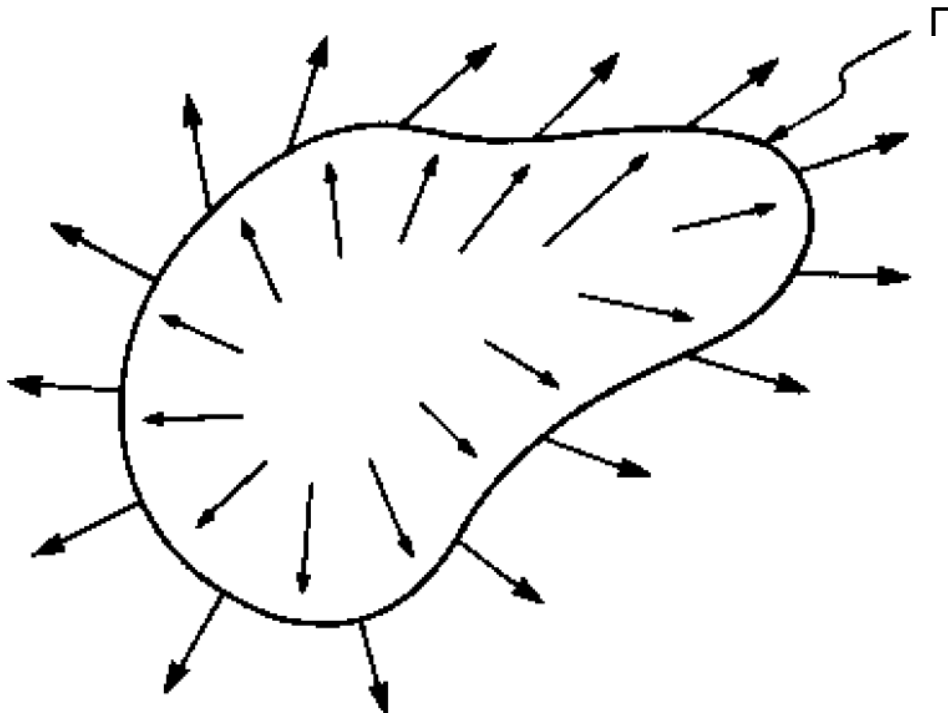

Figure 39: The Index concept.

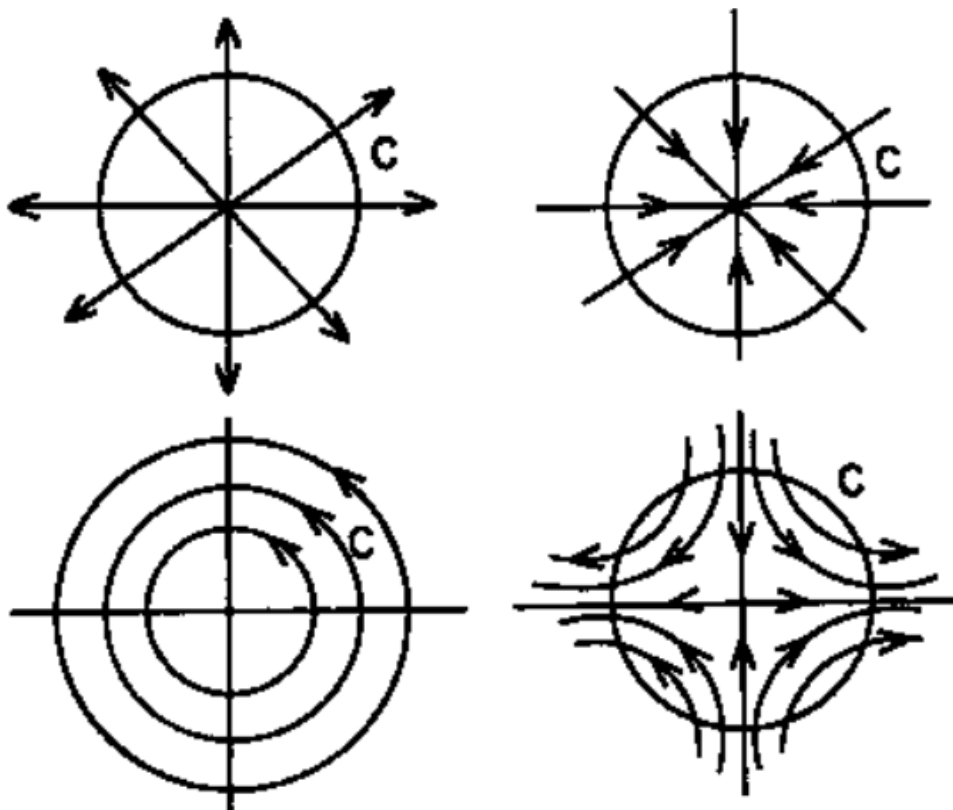

Figure 40: Four different vector fields and the index.

Here are some properties of the index (See Figure 40):

1. The Index is always an *integer* – this is because the angle at the beginning and end of  $\Gamma$  is the same and therefore the variation of  $\varphi$  is a multiple of  $2\pi$ .
2. If there are no fixed points (equilibria) in the interior of a simple closed curve  $\Gamma$  then  $I(\Gamma) = 0$ . To see this, cover the interior of  $\Gamma$  with a mesh and consider the boundary of each cell as an elementary curve  $\gamma_k$ . Since there is no fixed point in the interior of  $\Gamma$ , we know that no  $\gamma_k$  will have an angle increase – putting everything together we get the result for the whole  $\Gamma$ .
3. If  $\Gamma$  is a closed orbit of the system then  $I(\Gamma) = 1$  (this can be easily checked graphically).
4. Let  $\Gamma$  encircle anticlockwise an isolated fixed point  $\mathbf{x}^*$ . If  $\mathbf{x}^*$  is a saddle node, then  $I(\Gamma) = -1$ , otherwise  $I(\Gamma) = 1$ . In the case of fixed points, we also identify  $I(\Gamma)$  with  $I(\mathbf{x}^*)$ .
5. The index of a curve  $\Gamma$  surrounding a number of fixed points  $\mathbf{x}_1^*, \dots, \mathbf{x}_n^*$  is

$$I(\Gamma) = \sum_{k=1}^n I(\mathbf{x}_k^*)$$

6. The index of a closed trajectory enclosing fixed points  $\mathbf{x}_1^*, \dots, \mathbf{x}_n^*$  is

$$I(\Gamma) = \sum_{k=1}^n I(\mathbf{x}_k^*) = 1.$$

**Example 6.3.** Consider the system

$$\begin{aligned}\dot{x}_1 &= x_1(3 - x_1 - 2x_2) \\ \dot{x}_2 &= x_2(2 - x_1 - x_2)\end{aligned}$$

Does this system have any closed trajectories? First, note that the axes are trajectories. Let  $\mathbf{y} = (x_1, x_2)$ . This system has four fixed points:

- $\mathbf{y}_1^* = (0, 0)$  unstable node, so  $I(\mathbf{y}_1^*) = 1$ .

- $\mathbf{y}_2^* = (0, 2)$  stable node, so  $I(\mathbf{y}_2^*) = 1$ .
- $\mathbf{y}_3^* = (3, 0)$  unstable node, so  $I(\mathbf{y}_3^*) = 1$ .
- $\mathbf{y}_4^* = (1, 1)$  saddle point, so  $I(\mathbf{y}_4^*) = -1$ .

Any curve enclosing zero fixed points is not a trajectory. Also, a curve  $\Gamma$  enclosing only  $\mathbf{y}_4^*$  is not a trajectory as  $I(\Gamma) = 1$  and  $I(\mathbf{y}_4^*) = -1$ . Moreover, a curve  $\Gamma$  enclosing either  $\mathbf{y}_1^*$  or  $\mathbf{y}_2^*$  or  $\mathbf{y}_3^*$  and any combination of them is not a trajectory as any such curve would need to intersect at least one of the axes, each of which is a trajectory. Since trajectories cannot intersect, it means that  $\Gamma$  is not a trajectory. See Figure 41.

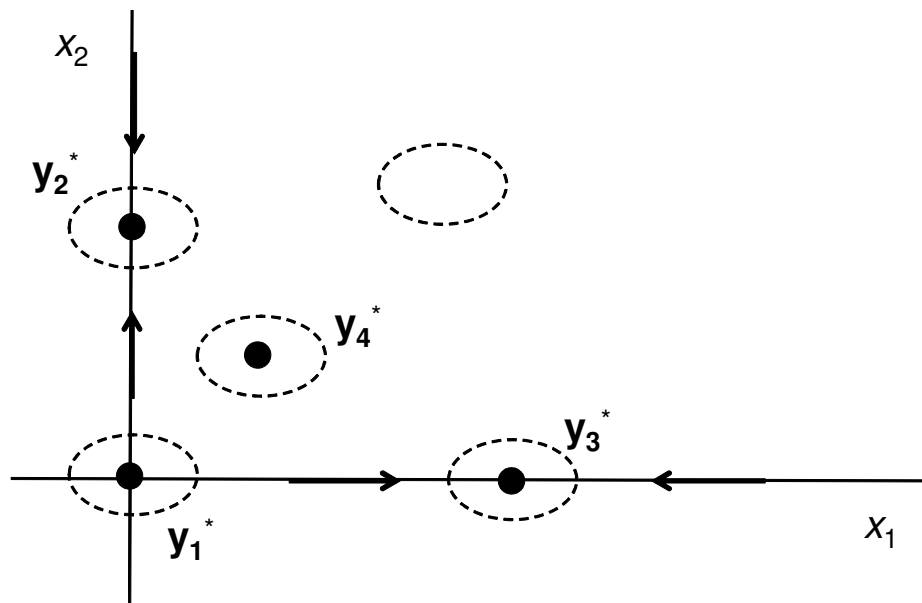

Figure 41: The phase plane of Example 41.

Going back to the Duffing oscillator of Example 6.2, which of the vector fields in Figure 38 are possible?

## 6.4 Limit cycles

Limit cycles are *isolated* periodic orbits. They can be stable or unstable – in this section we will discuss the concept of *orbital* stability.

**Definition 6.4.** A periodic orbit  $\Gamma$  is said to be *stable* if for every  $\epsilon > 0$  there is a neighbourhood  $U$  of  $\Gamma$  such that for all  $\mathbf{x} \in U$ , the distance between  $\phi(t, \mathbf{x})$  and  $\Gamma$  is less than  $\epsilon$ . Moreover,  $\Gamma$  is called *asymptotically stable*, if it is stable and if for all points  $\mathbf{x} \in U$  we have that this distance tends to zero as  $t \rightarrow \infty$ .

Recall that a *centre* consists of a family of periodic orbits. Each periodic orbit in this family is stable, but not asymptotically stable. In fact, a periodic orbit

$$\Gamma : \mathbf{x} = \gamma(t), \quad 0 \leq t \leq T$$

is asymptotically stable only if

$$\int_0^T \nabla \cdot \mathbf{f}(\gamma(t)) dt \leq 0.$$

In line with the attractor definitions discussed in the previous lecture, an asymptotically stable cycle is referred to as an  $\omega$ -limit cycle.

For systems on the plane, a limit cycle  $\Gamma$  is a cycle which is the  $\alpha$  or  $\omega$  limit set of some trajectory of (6.1) other than  $\Gamma$ . If it is the  $\omega$ -limit set of every trajectory in the neighbourhood of  $\Gamma$  then it is a *stable limit cycle*; similarly, if it is the  $\alpha$ -limit set of every trajectory in some neighbourhood of  $\Gamma$  then it is an *unstable limit cycle*. Lastly, it may happen that  $\Gamma$  is the  $\alpha$ -limit set of one trajectory and the  $\omega$ -limit set of another – in that case  $\Gamma$  is called a *semi-stable limit cycle*.

**Example 6.4.** Consider the system

$$\begin{aligned} \dot{x} &= -y + x(1 - x^2 - y^2)^2 \\ \dot{y} &= x + y(1 - x^2 - y^2)^2 \end{aligned}$$

Transforming this into polar coordinates we get:

$$\begin{aligned} \dot{r} &= r(1 - r^2)^2 \\ \dot{\theta} &= 1 \end{aligned}$$

It is obvious that for  $r < 1$ ,  $\dot{r} > 0$  and for  $r > 1$ , again,  $\dot{r} > 0$ , but at  $r = 1$ ,  $\dot{r} = 0$ ! In this case, we have a semi-stable limit cycle. See Figure 42.

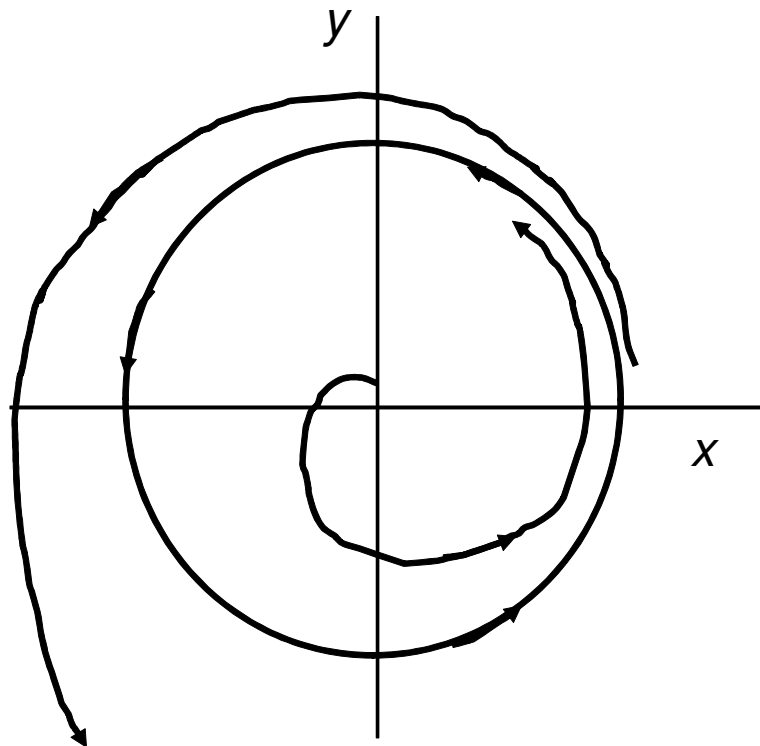

Figure 42: A semi-stable limit cycle.

The most important tool for studying stability of limit cycles is the so-called Poincaré Map.

## 6.5 The Poincaré Map

Suppose  $\Gamma$  is a periodic orbit of (6.1) through a point  $\mathbf{x}_0$ , and  $\Sigma$  is a hyperplane perpendicular to  $\Gamma$  at  $\mathbf{x}_0$ . Consider now any point  $\mathbf{x} \in \Sigma$  close to  $\mathbf{x}_0$ , and the solution  $\phi(t, \mathbf{x})$ . This solution will cross  $\Sigma$  several times – denote the point on  $\Sigma$  where  $\phi(t, \mathbf{x})$  will pierce  $\Sigma$  by  $\mathbf{P}(\mathbf{x})$  and so on. The mapping

$$\mathbf{x} \mapsto \mathbf{P}(\mathbf{x})$$

is called a *Poincaré Map*. See Figure 43.

The map  $\mathbf{P}$  has several nice properties, the most important of which is that equilibria of  $\mathbf{P}$  correspond to the periodic orbits of (6.1). There are several

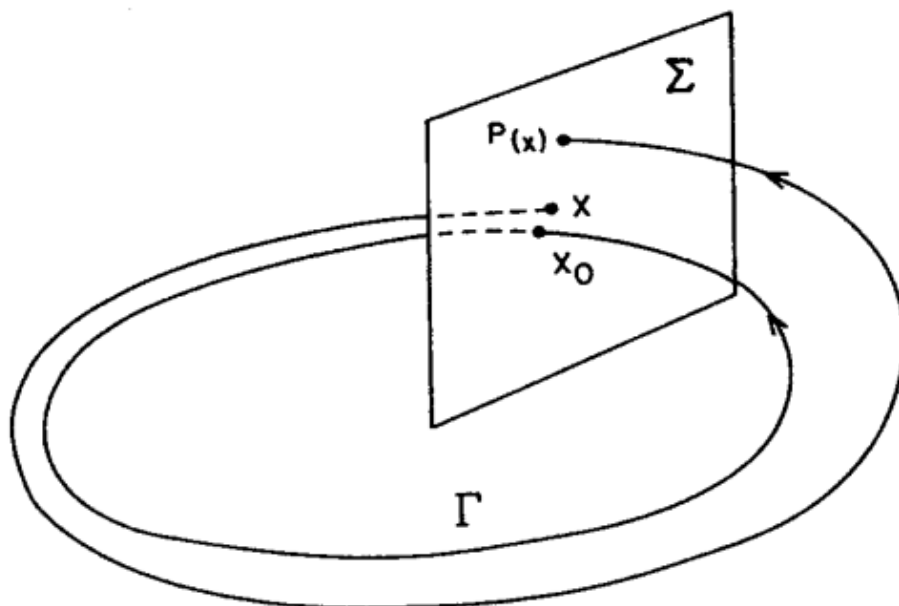

Figure 43: The Poincaré Map concept.

other important properties of Poincaré Maps which are beyond the scope of this course.

**Example 6.5.** Recall from Example 5.5 that the system

$$\begin{aligned}\dot{x} &= -y + x(1 - x^2 - y^2) \\ \dot{y} &= x + y(1 - x^2 - y^2)\end{aligned}$$

can be written in polar coordinates as

$$\begin{aligned}\dot{r} &= r(1 - r^2) \\ \dot{\theta} &= 1.\end{aligned}$$

The limit cycle is at  $r = 1$ ; in fact this is a stable attractor for the whole of  $\mathbb{R}^2$  minus the origin. The first equation can be solved to give

$$r(t, r_0) = \left[ 1 + \left( \frac{1}{r_0^2} - 1 \right) e^{-2t} \right]^{-1/2}$$

and

$$\theta(t, \theta_0) = t + \theta_0.$$

Define by  $\Sigma$  the ray  $\theta = \theta_0$  that goes through the origin. This line is pierced

every  $t = 2\pi$ , hence the Poincaré Map is given by

$$P(r_0) = \left[ 1 + \left( \frac{1}{r_0^2} - 1 \right) e^{-4\pi} \right]^{-1/2}$$

Obviously  $P(1) = 1$ , a fixed point. Its stability will depend on  $P'(1)$ , which can be evaluated to be

$$P'(1) = e^{-4\pi} < 1$$

See Figure 44.

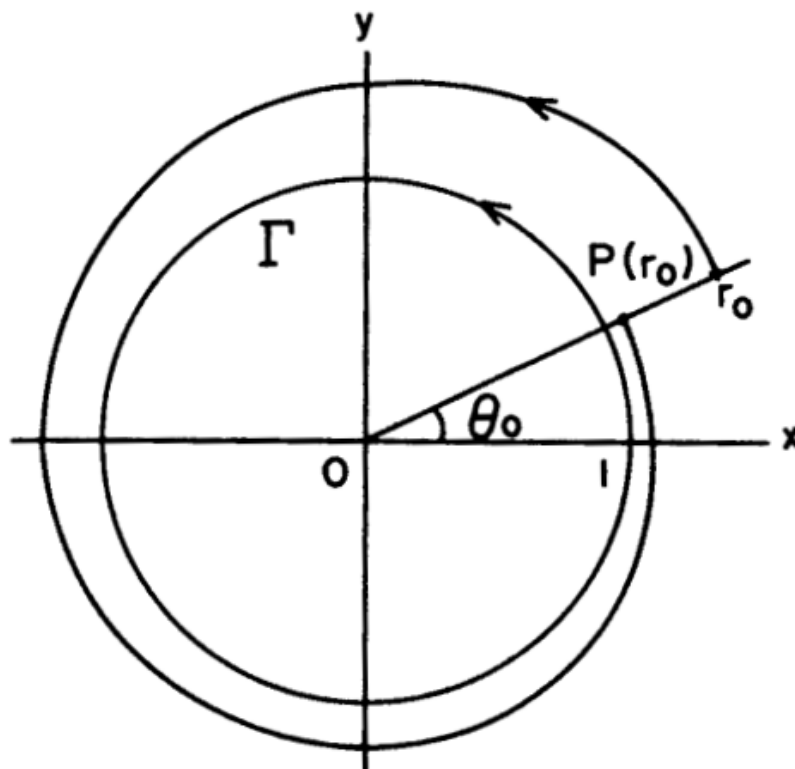

Figure 44: The Poincaré Map of Example 6.5.

## 7 Bifurcations

So far we have looked at the local and global behaviour of trajectories of nonlinear dynamical systems of the form

$$\dot{\mathbf{x}} = \mathbf{f}(\mathbf{x})$$

In this lecture we will consider how the behaviour of this system changes as  $\mathbf{f}(\mathbf{x})$  changes. In particular, we consider dynamical systems of the form

$$\dot{\mathbf{x}} = \mathbf{f}(\mathbf{x}, \boldsymbol{\mu})$$

when the parameter  $\boldsymbol{\mu} \in \mathbb{R}^p$  changes the *structural stability* of the vector field (i.e. the qualitative behaviour of the system changes drastically). The variables  $\boldsymbol{\mu}$  are called *bifurcation* parameters.

### 7.1 One-dimensional Bifurcations

We first concentrate on one-dimensional bifurcations. The simplest systems that can exhibit these bifurcations are one-dimensional systems. Consider the system

$$\dot{x} = f(x, \mu)$$

with  $\mu, x \in \mathbb{R}$ . A *bifurcation* occurs when the number or type of equilibria changes as we vary the parameter  $\mu$ . There are three types of bifurcations: *saddle-node*, *transcritical* and *pitchfork*.

#### Saddle-node bifurcation

The normal form of a dynamical system that could undergo a saddle-node bifurcation is

$$\dot{x} = \mu - x^2$$

For this system, if  $\mu > 0$  there are two fixed points, one stable and one unstable, that collide into a saddle point when  $\mu = 0$ ; for  $\mu < 0$  the saddle point vanishes.

The above behaviour is usually depicted using a *bifurcation diagram*, which shows the position of the fixed points on the  $x$ -axis versus the parameter  $\mu$ .

A *solid line* is used to denote how the *stable* fixed point varies as a function of  $\mu$ , while a *dotted line* is used to show the variation of an unstable equilibrium versus  $\mu$ . See Figure 45.

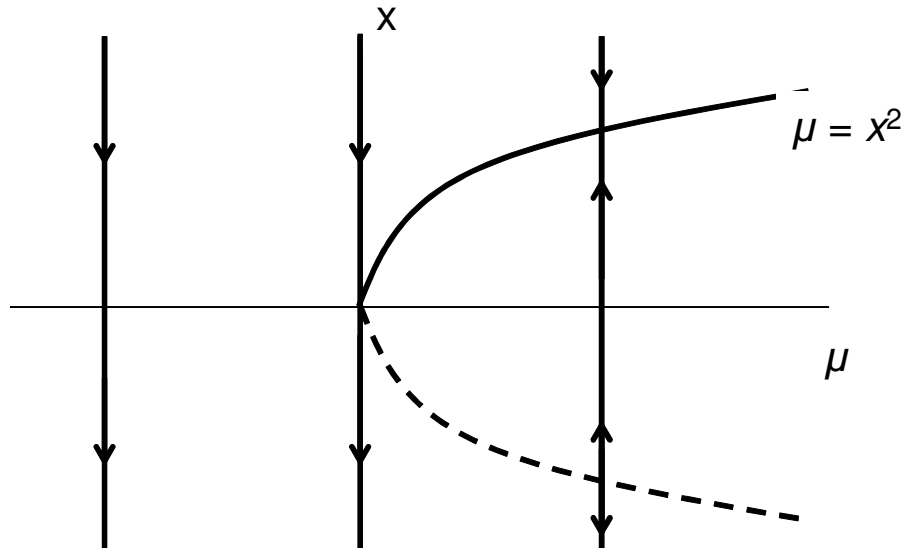

Figure 45: A Saddle-Node bifurcation.

### Transcritical Bifurcation

The normal form of a dynamical system that could undergo a transcritical bifurcation is

$$\dot{x} = \mu x - x^2$$

This system has two equilibria, one at  $x^* = 0$  and one at  $x^* = \mu$ , one stable and one unstable, depending on the value of  $\mu$ . At  $\mu = 0$  the two fixed points merge into a saddle-point; on either side of  $\mu = 0$ , the stability properties of the two equilibria are 'exchanged'. See Figure 46.

### Pitchfork Bifurcation

The normal form in this case is

$$\dot{x} = \mu x - x^3$$

For  $\mu < 0$  there is only one equilibrium point, at  $x = 0$ , which at  $\mu = 0$  'breaks' into 3 equilibria, with the  $x = 0$  equilibrium changing stability properties, while

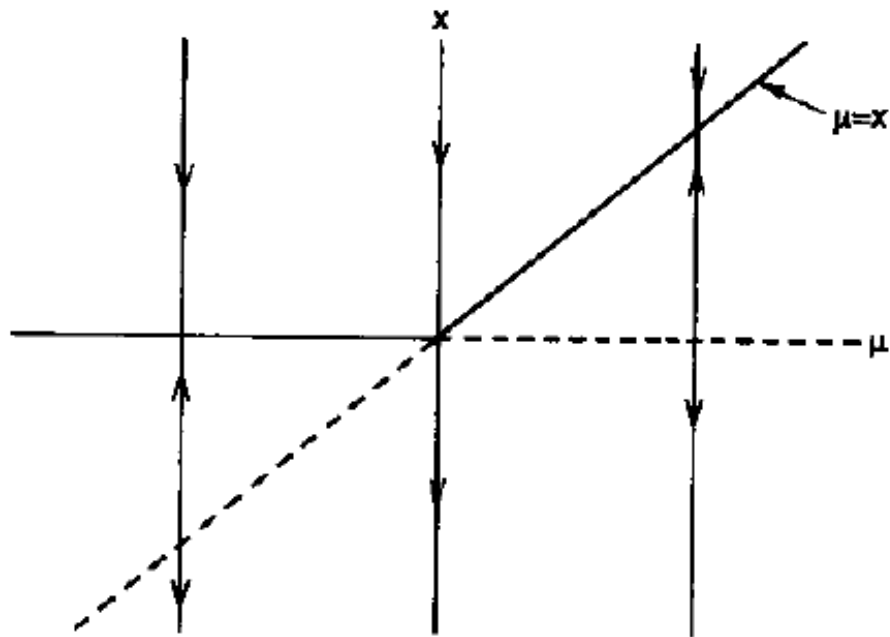

Figure 46: A Transcritical bifurcation.

the other two fixed points having the same equilibrium properties as the ones of the  $x^* = 0$  equilibrium for  $\mu < 0$ . The name of the bifurcation is obvious from the shape of the bifurcation diagram - see Figure 47!

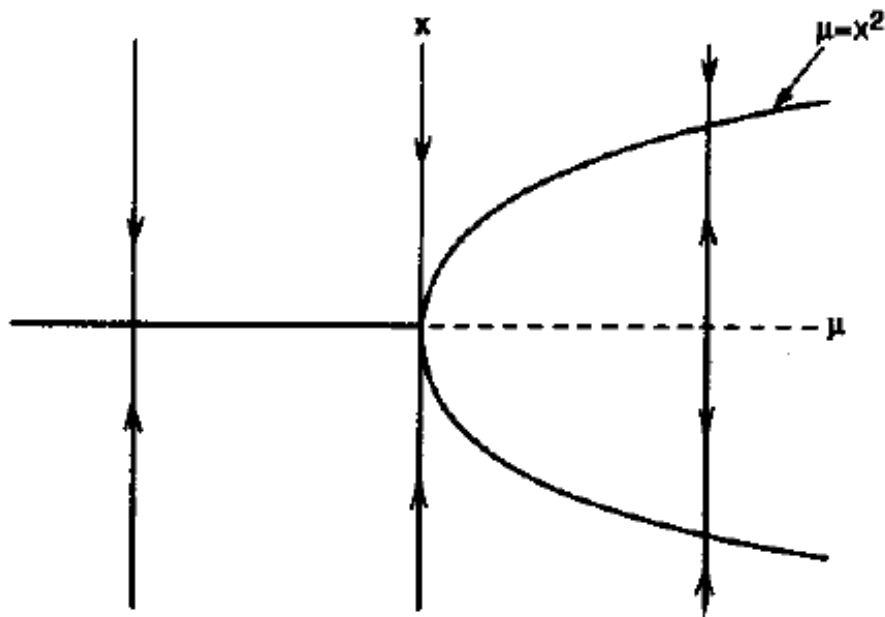

Figure 47: A Pitchfork bifurcation.

## Tangency Conditions

How can we decide when a bifurcation occurs? The ‘bifurcation point’, i.e. the point where the nature of the stability of the equilibria changes can be found by considering a set of *tangency conditions*. All the above bifurcations share a certain tangency property of  $f(x)$  to the  $x$ -axis: therefore we can locate candidate points  $(x_0, \mu_0)$  for bifurcation events by solving the following system of equations:

$$\begin{aligned} f(x_0, \mu_0) &= 0 \\ f_x(x_0, \mu_0) &= 0 \end{aligned}$$

where  $f_x \triangleq \frac{\partial f}{\partial x}$ . Once such bifurcation candidates have been identified, then certain sufficient conditions can be used to classify the type of bifurcation, as follows:

- **Saddle Node bifurcation:**

$$\begin{aligned} f(x_0, \mu_0) &= 0 \\ f_x(x_0, \mu_0) &= 0 \\ f_\mu(x_0, \mu_0) &\neq 0 \\ f_{xx}(x_0, \mu_0) &\neq 0 \end{aligned}$$

- **Transcritical bifurcation:**

$$\begin{aligned} f(x_0, \mu_0) &= 0 \\ f_x(x_0, \mu_0) &= 0 \\ f_\mu(x_0, \mu_0) &= 0 \\ f_{xx}(x_0, \mu_0) &\neq 0 \\ f_{x\mu}(x_0, \mu_0) &\neq 0 \end{aligned}$$

- **Pitchfork bifurcation:**

$$\begin{aligned}
 f(x_0, \mu_0) &= 0 \\
 f_x(x_0, \mu_0) &= 0 \\
 f_\mu(x_0, \mu_0) &= 0 \\
 f_{xx}(x_0, \mu_0) &= 0 \\
 f_{x\mu}(x_0, \mu_0) &\neq 0 \\
 f_{xxx}(x_0, \mu_0) &\neq 0
 \end{aligned}$$

One can then devise an 'algorithm' for classifying bifurcations by checking all derivatives as shown above and then deciding which type it 'fits' better.

The above sufficient conditions can be derived rigorously using the 'implicit function theorem' - this is beyond the scope of this course.

**Example 7.1.** Consider the system

$$\dot{x} = \mu \ln x + x - 1$$

Let  $f(x, \mu) = \mu \ln x + x - 1$  then  $f_x(x, \mu) = \frac{\mu}{x} + 1$ . The solution of the system

$$\begin{aligned}
 f(x_0, \mu_0) &= 0 \\
 f_x(x_0, \mu_0) &= 0
 \end{aligned}$$

is

$$\begin{aligned}
 -x \ln x + x - 1 &= 0 \\
 \mu &= -x
 \end{aligned}$$

The first equation has a unique solution at  $x = 1$  (how do you show that?), hence a bifurcation can only occur when  $(x_0, \mu_0) = (1, -1)$ . Note also that

$$\begin{aligned}
 f_\mu(x, \mu) = \ln x &\Rightarrow f_\mu(1, -1) = \ln 1 = 0 \\
 f_{x\mu}(x, \mu) = \frac{1}{x} &\Rightarrow f_{x\mu}(1, -1) = 1 \neq 0 \\
 f_{xx}(x, \mu) = -\frac{\mu}{x^2} &\Rightarrow f_{xx}(1, -1) = 1 \neq 0
 \end{aligned}$$

Therefore there is a transcritical bifurcation at  $(x_0, \mu_0) = (1, -1)$ .

The above bifurcations can happen for higher-dimensional systems, with the bifurcations happening on a one-dimensional subspace of the higher dimensional system under study.

**Example 7.2.** Does the origin of the system

$$\begin{aligned}\dot{x} &= \mu x + y + \sin x \\ \dot{y} &= x - y\end{aligned}$$

undergo any bifurcation as  $\mu$  varies? Linearizing about the  $(0, 0)$  equilibrium, we get

$$J = \begin{bmatrix} \mu + 1 & 1 \\ 1 & -1 \end{bmatrix}$$

which is a stable node for  $\mu < -2$  (use the determinant condition) and a saddle if  $\mu > -2$ . In fact, around  $\mu = -2$  there may be other equilibria - indeed, since  $x^* = y^*$ , the equation

$$\mu x^* + x^* + \sin x^* = 0$$

reveals one equilibrium for  $\mu < -2$  and three for  $\mu > -2$ . See Figure 48 for the bifurcation diagram and Figure 49 for the phase plane, for  $\mu$  slightly smaller and slightly larger than  $-2$ .

## 7.2 Hopf Bifurcations

Consider a two-dimensional system

$$\begin{aligned}\dot{x} &= f(x, y, \mu) \\ \dot{y} &= g(x, y, \mu)\end{aligned}$$

Suppose, just as in the one-dimensional case, that  $(x^*(\mu), y^*(\mu))$  is an equilibrium as a function of  $\mu$ . Let  $\lambda_1(\mu)$  and  $\lambda_2(\mu)$  be the eigenvalues of the linearization of the system about this equilibrium. If these eigenvalues are real, then the type of bifurcation we would expect would be similar in kind to one of the cases seen in the one-dimensional case. If they are complex, however, then we could get something more interesting.

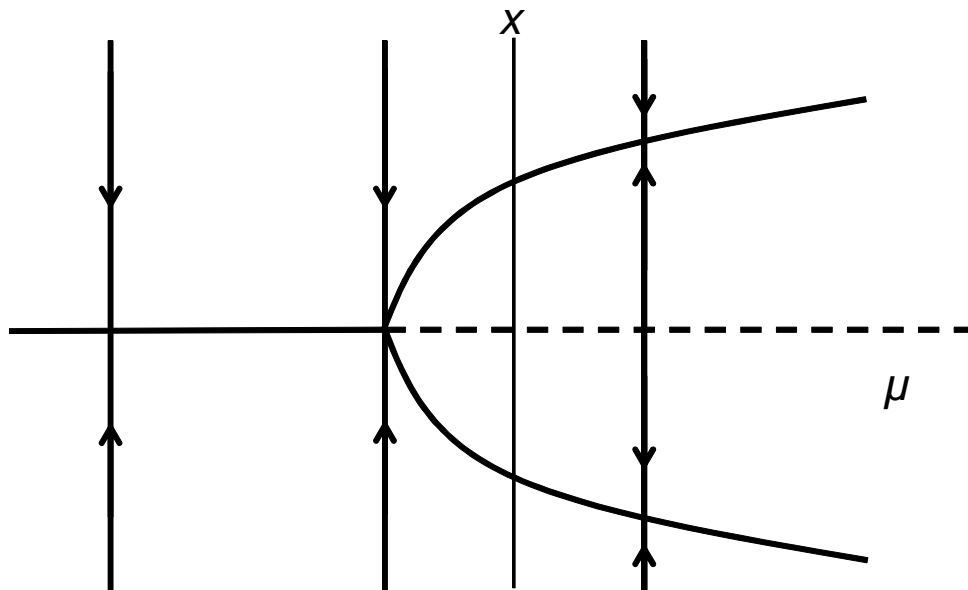

Figure 48: The bifurcation diagram for Example 7.2

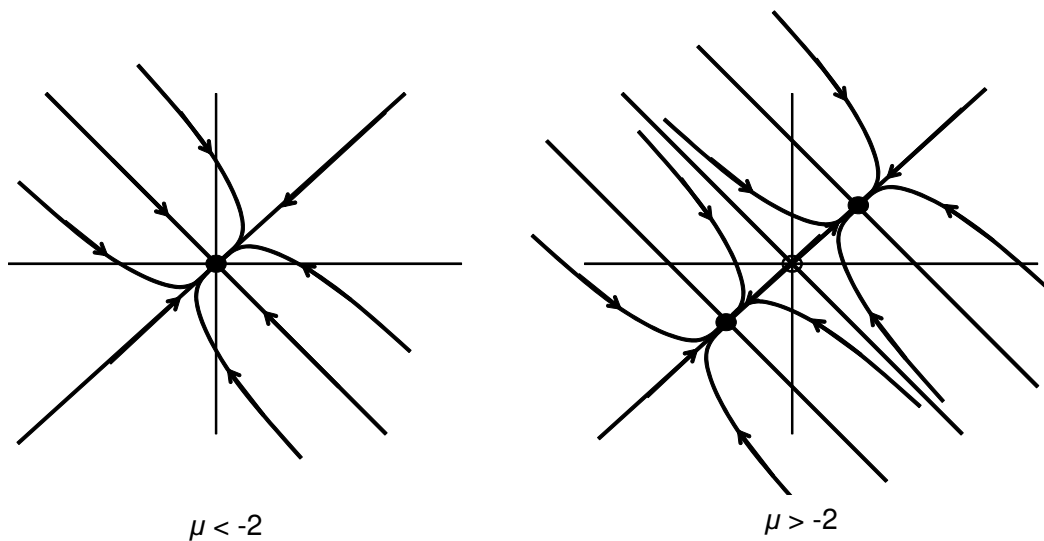

Figure 49: The phase plane for Example 7.2

We say that this system undergoes a *Hopf* bifurcation at  $\mu = \mu_0$  if the following conditions are satisfied:

1. For  $\mu < \mu_0 + \epsilon$  and  $\mu > \mu_0 - \epsilon$  for  $\epsilon > 0$ ,

$$\lambda_{1,2}(\mu) = \alpha(\mu) \pm j\omega(\mu)$$

2.  $\alpha(\mu_0) = 0$ .
3.  $\alpha(\mu) < 0$  for  $\mu < \mu_0$ .

4.  $\alpha(\mu) > 0$  for  $\mu > \mu_0$ .

See Figure 50.

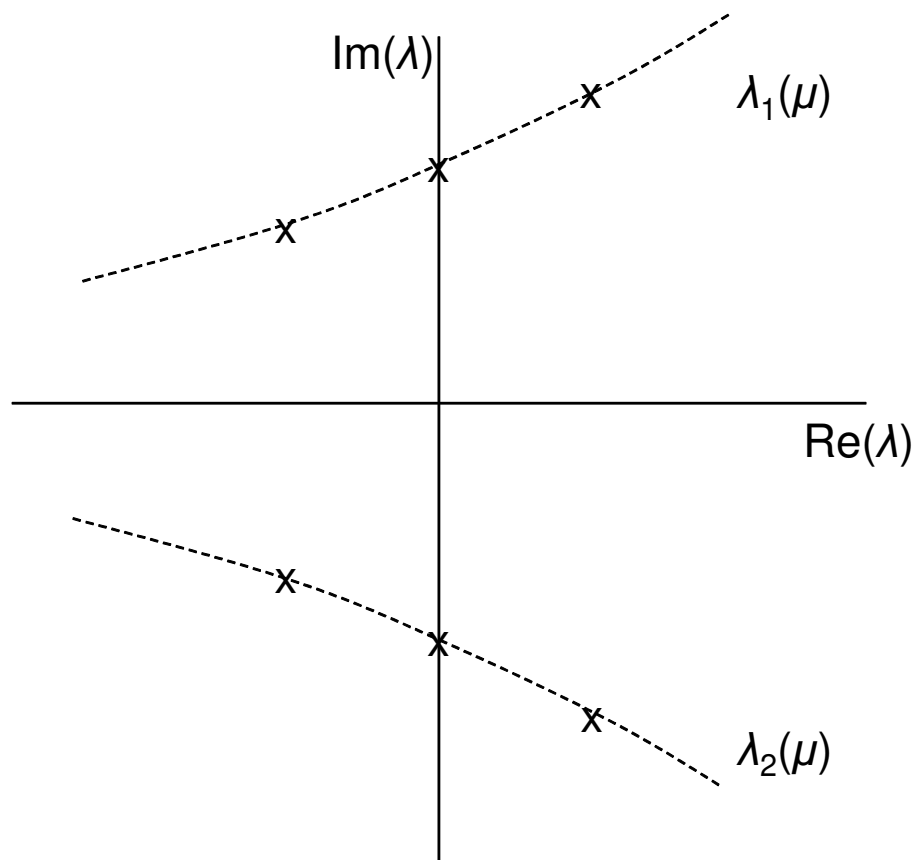

Figure 50: The Eigenvalue Diagram during a Hopf Bifurcation.

There are three different types of Hopf Bifurcation:

- *Supercritical* Hopf bifurcation: For  $\mu < \mu_0$  we have a stable spiral fixed point, which for  $\mu > \mu_0$  becomes an unstable spiral. The unstable spiral is bounded by a stable limit cycle which expands with increasing  $\mu$ . See Figure 51. [Supercritical here means that a limit cycle appears/disappears during the bifurcation, which is stable.]
- *Subcritical* Hopf bifurcation: For  $\mu < \mu_0$  a stable spiral is surrounded by an unstable limit cycle which decreases in size as  $\mu$  increases. At  $\mu = \mu_0$  the cycle collapses to a fixed point, and for  $\mu > \mu_0$  it becomes as an unstable spiral. See Figure 52. [Subcritical here means that a limit cycle appears/disappears during the bifurcation, which is unstable.]

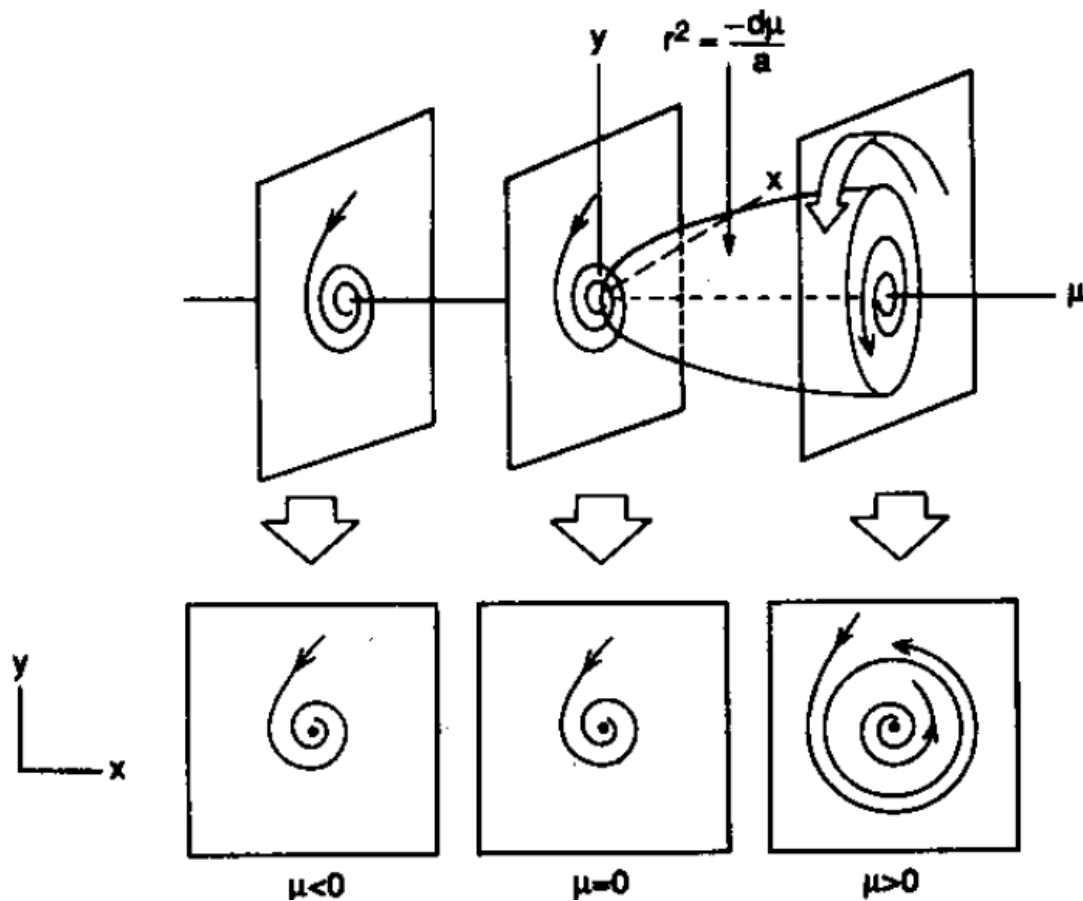

Figure 51: A Supercritical Hopf Bifurcation.

- *Degenerate* Hopf bifurcation: A stable spiral for  $\mu < \mu_0$  becomes a non-linear centre at  $\mu = \mu_0$  and then an unstable spiral for  $\mu > \mu_0$ . There is no limit cycle at either  $\mu < \mu_0$  or  $\mu > \mu_0$ , hence the name 'degenerate'.

The normal form for a Hopf bifurcation is

$$\begin{aligned}\dot{x}_1 &= \mu x_1 - x_2 + \sigma x_1(x_1^2 + x_2^2) \\ \dot{x}_2 &= x_1 + \mu x_2 + \sigma x_2(x_1^2 + x_2^2)\end{aligned}$$

This system undergoes a Hopf bifurcation at  $(0, 0)$  when  $\mu = 0$  (see examples paper). This bifurcation is

- Supercritical if  $\sigma = -1$ .
- Subcritical if  $\sigma = 1$ .
- Degenerate if  $\sigma = 0$ .

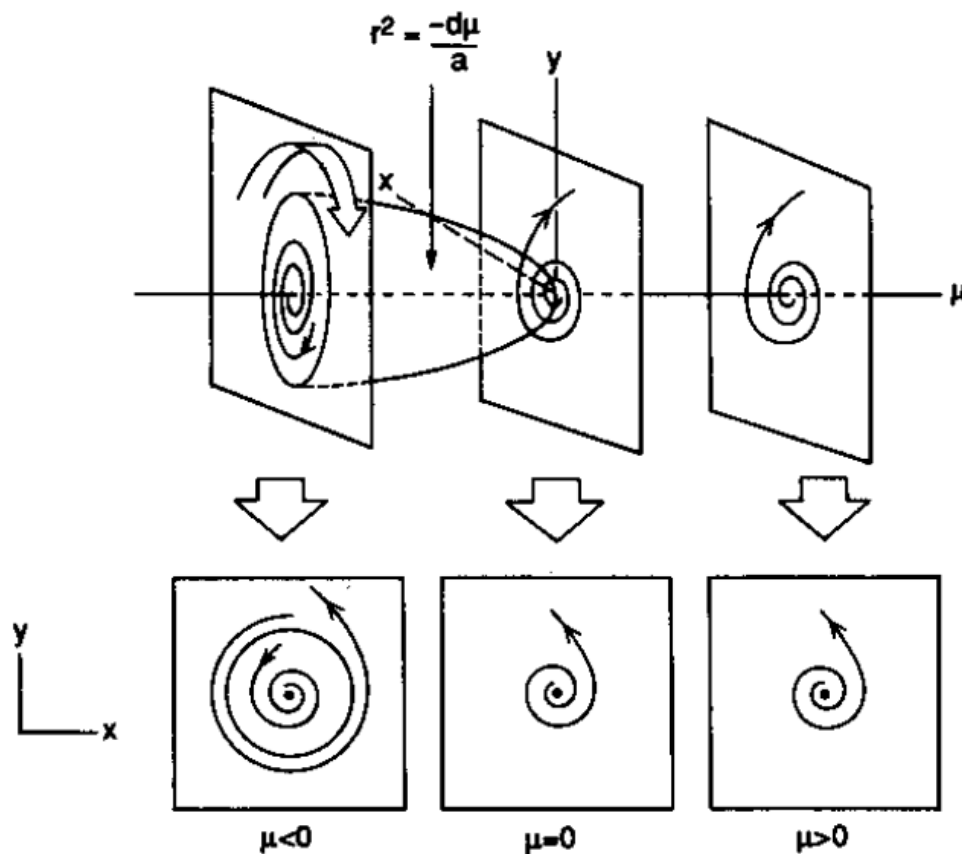

Figure 52: A Subcritical Hopf Bifurcation.

A simple way to classify the type of Hopf bifurcation is to use polar coordinates.

**Example 7.3.** Consider the system

$$\begin{aligned}\dot{x} &= \mu x - y + xy^2 \\ \dot{y} &= x + \mu y + y^3\end{aligned}$$

Consider the zero equilibrium; the Jacobian becomes

$$\begin{bmatrix} \mu & -1 \\ 1 & \mu \end{bmatrix}$$

with eigenvalues at  $\mu \pm j$ . Therefore there is a Hopf bifurcation at  $(0, 0)$ .

Let  $r^2 = x^2 + y^2$ . Then we have:

$$r\dot{r} = x\dot{x} + y\dot{y} = x(\mu x - y + xy^2) + y(x + \mu y + y^3) = \mu r^2 + r^2 y^2.$$

If  $\mu > 0$  then the eigenvalues have positive real parts; and since

$$\dot{r} = \mu r + r y^2 \geq \mu r$$

this means that  $\lim_{t \rightarrow \infty} r(t) = +\infty$ , i.e. there is no limit cycle when  $\mu > 0$ .

If  $\mu = 0$  then  $\dot{r} = ry^2 > 0$  so  $r(t)$  is strictly increasing with no nonlinear centre. Hence bifurcation is not degenerate.

Hence bifurcation is subcritical, as an unstable limit cycle appears for  $\mu < 0$ .

There are more types of bifurcations, which are however beyond the scope of this course.

## 8 Chaos

In this lecture we will consider so-called *chaotic* systems. We will first discuss the case of chaos in discrete-time systems, before we discuss briefly chaos in continuous time systems. The reason we discuss discrete-time systems first, is that we can have chaotic dynamics even if the dynamical system is one-dimensional, if it is in discrete time.

### 8.1 Chaos in Maps

Certain maps are the simplest examples of chaos: the ‘trajectory’ of a map is discrete and can ‘jump’ from one point to another. It is therefore expected that more interesting behaviour can be exhibited in the case of maps.

Consider a map of the form

$$x_{k+1} = F(x_k)$$

and recall from Lecture 2 that if  $x^* = F(x^*)$  then  $x^*$  is a fixed point. To determine the stability of a map equilibrium we can proceed just as in the case of a continuous-time system; linearization results in

$$w_{k+1} = DF(x^*)w_k$$

and the position of the eigenvalues with respect to *the unit circle* determine the stability of the equilibrium for the original map, unless the equilibrium is not hyperbolic, which means that one of the eigenvalues has a modulus of 1. Recall our discussion on stable, unstable and centre subspaces, as these were analyzed in Question 2 of Examples Sheet 1.

### Cobwebs

One way to understand the far from equilibrium behaviour of a system under study, is to construct a *cobweb*. Given a map

$$x_{k+1} = f(x_k)$$

and an initial condition  $x_0$ , we draw on the  $x$ -axis  $x_k$ , and on the  $y$ -axis  $x_{k+1}$ . For example,  $x_1$  will be the value of  $f(x_0)$ , and that can be found by

drawing a vertical line from  $x_0$  until it intersects  $f(x)$ . To find  $f(x_2)$ , we start from  $x_1$ , which can be found on the diagonal line  $x_{k+1} = x_k$  and then move vertically to find  $f(x_2)$ . See Figure 53.

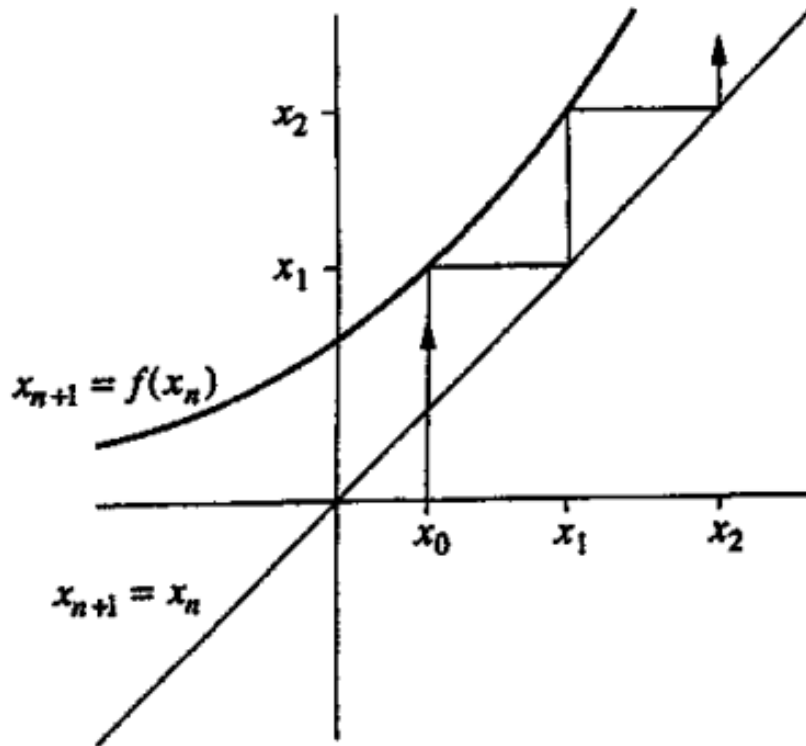

Figure 53: A cobweb example.

**Example 8.1.** Consider the system  $x_{k+1} = \cos x_k$ . The cobweb shows that a trajectory spirals in a fixed point around 0.739, which is the equilibrium point. See Figure 54 for the cobweb in this case.

## Logistic Equation

One of the most important one-dimensional maps is the *logistic map*:

$$x_{k+1} = rx_k(1 - x_k)$$

which is used to model population growth (a single species striving for its own food). There are two equilibria in this case, one of which is  $x^* = 0$  and the other is at  $x^* = (1 - \frac{1}{r})$ . Linearization produces

$$w_{k+1} = (r - 2rx^*)w_k$$

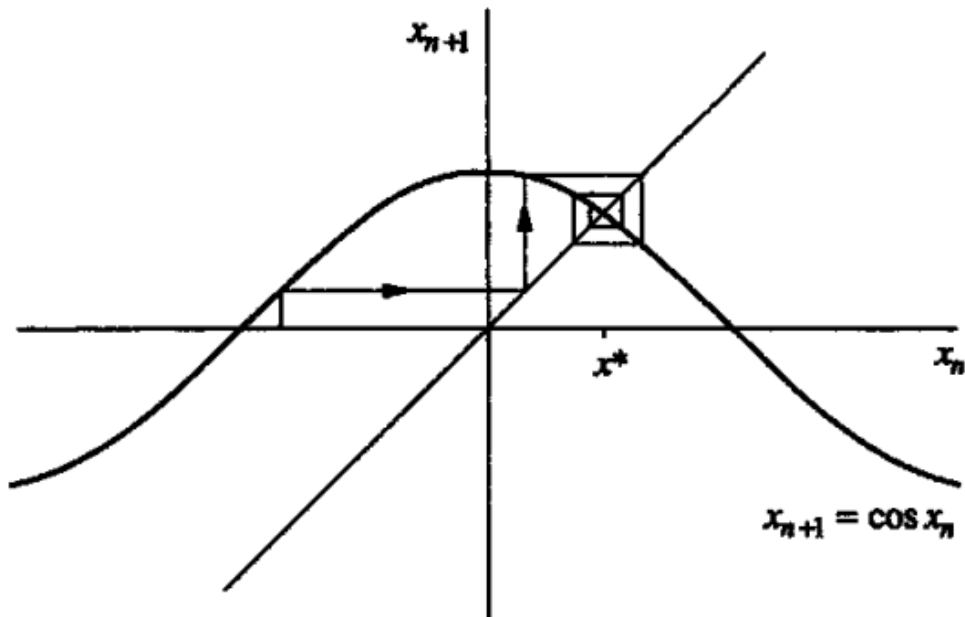

Figure 54: The cobweb for example 8.1.

and so the  $x^* = 0$  equilibrium is stable for  $r < 1$ . In order to understand what happens globally, one can use a cobweb to see that in the case of  $r < 1$ , the population always goes extinct. See Figure 55.

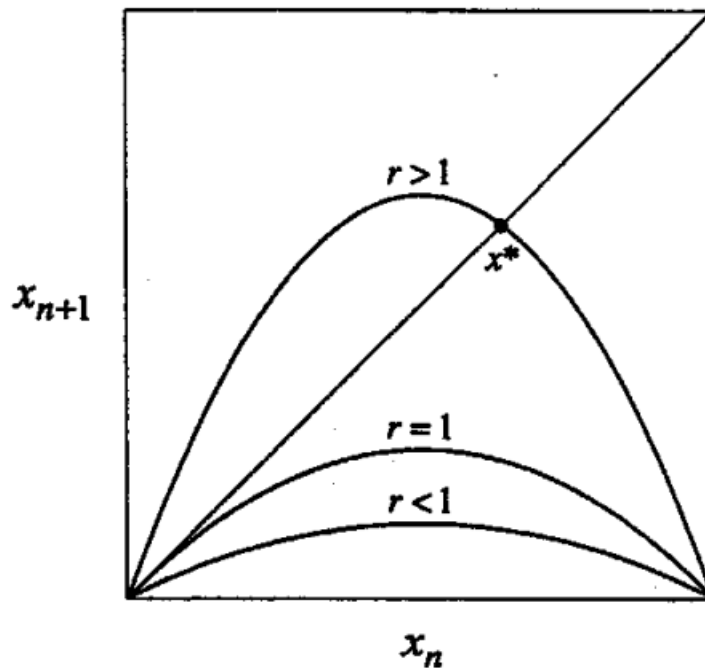

Figure 55: The cobweb for the logistic equation,  $r < 1$ .

More interesting behaviour occurs for values of  $r > 1$ , when the 0 equilibrium is unstable. What happens to the other equilibrium?

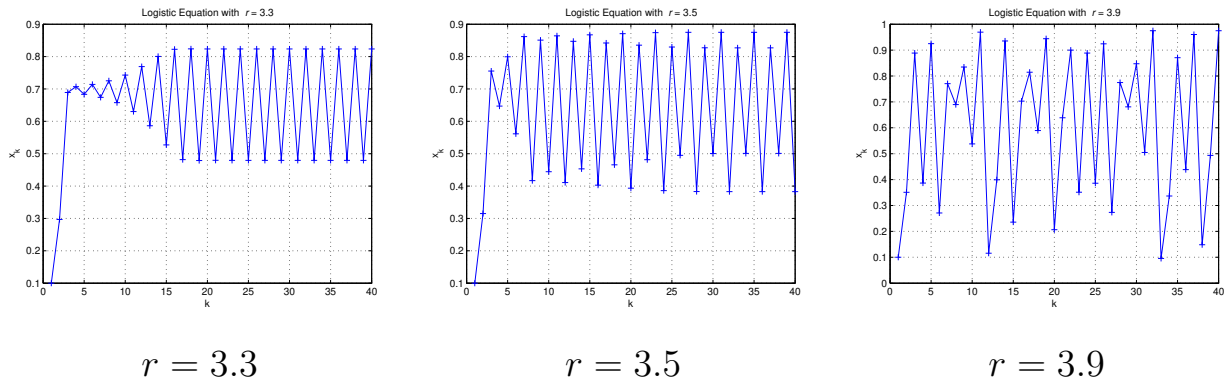

Figure 56: Simulations of the logistic equation for different values of  $r$ .

It turns out that for  $1 < r < 3$  the system behaves as shown in Figure 56. In fact the second equilibrium at  $(1 - \frac{1}{r})$  is stable for  $1 < r < 3$  while for  $r > 3$  one gets oscillations, whose period with increasing  $r$  *doubles*, in the sense that the cycle repeats every four rather than two generations. As  $r$  increases further this continues to double and bifurcations become faster and faster! In fact, for  $r > 3.569946\dots$  the sequence *is not periodic*. An *orbit diagram* shows not only the period doubling just described, but also that there are *periodic windows* between chaotic regions – and if you ‘zoom in’ those regions then a miniature copy of the orbit diagram appears... See Figure 57.

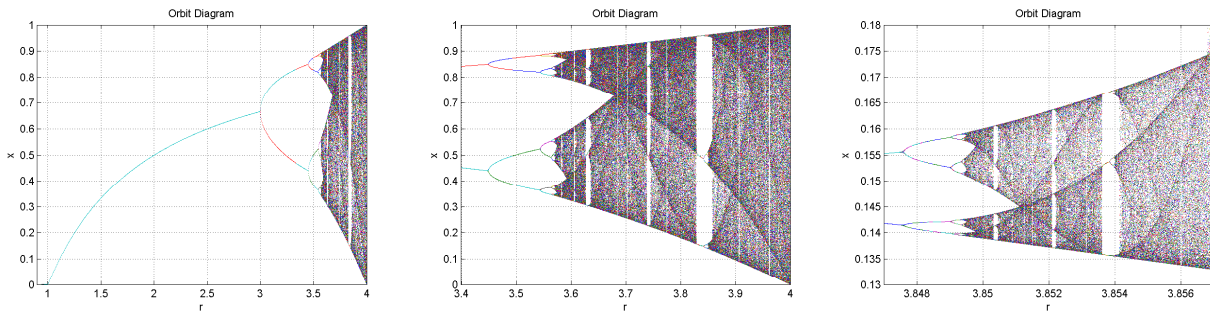

Figure 57: Orbit diagrams for the logistic equation for different ranges of  $r$ .

Two questions arise: first, how can we analyze the behaviour of the logistic map in the regime where there seems to be ‘order’ and how do we characterize the more ‘chaotic’ behaviour?

To understand, e.g., the stability of the 2-cycle, we can construct the *second-iterate map*

$$x_{k+2} = f(f(x_k)) = g(x_k)$$

and consider the stability of the equilibrium of interest. The equilibrium satisfies

$$r^2 x^*(1 - x^*)[1 - rx^*(1 - x^*)] = x^*$$

whose roots are  $0$ ,  $(1 - 1/r)$  and

$$x^* = \frac{r + 1 + \sqrt{(r - 3)(r + 1)}}{2r}, \quad x^* = \frac{r + 1 - \sqrt{(r - 3)(r + 1)}}{2r}$$

Linearizing the double map around these equilibria we can obtain the region where the 2-cycle is stable, and this happens at

$$3 < r < 1 + \sqrt{6}.$$

In the same way, we can calculate when the period doubles again etc., but this quickly gets very complicated.

### Lyapunov exponents

How do we know whether the aperiodic behaviour of the logistic map is *chaotic*? For that, we need sensitivity on initial conditions: nearby initial conditions separate exponentially fast on average. For example, consider two initial conditions,  $x_0$  and  $x_0 + w_0$  with  $w_0$  small. Let  $w_k$  denote the  $k$ th separation. If the separation grows exponentially fast, i.e.,  $|w_k| \simeq |w_0|e^{\lambda k}$  with  $\lambda > 0$  then we have chaos. The parameter  $\lambda$  is called the *Lyapunov exponent*. Obviously,

$$f(x_0 + w_0) \simeq f(x_0) + f'(x_0)w_0$$

and so

$$x_1 + w_1 = f(x_0 + w_0) = f(x_0) + f'(x_0)w_0$$

and therefore  $w_1 = f'(x_0)w_0$ . In a similar fashion we obtain that  $w_2 = f'(x_1)w_1$  etc, and so

$$w_k = \prod_{i=1}^{k-1} f'(x_i)w_0$$

The Lyapunov exponent can then be calculated as

$$\lambda = \frac{1}{k} \sum_{i=1}^{k-1} \ln |f'(x_i)|$$

and the limit as  $k \rightarrow \infty$  is the Lyapunov exponent. See Figure 58 for how the Lyapunov exponent varies with  $r$ .

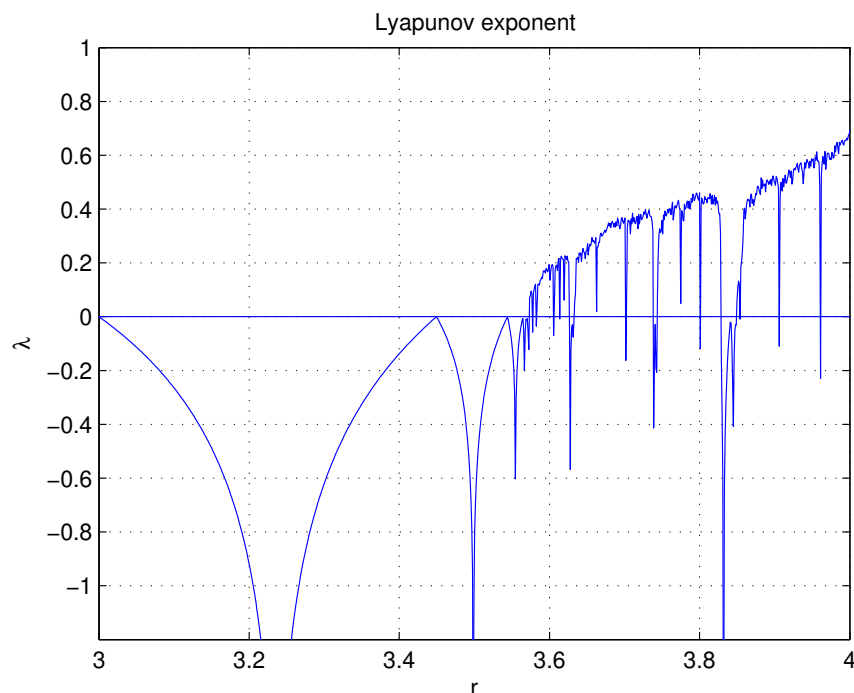

Figure 58: The Lyapunov exponent for the Logistic map.

## 8.2 Chaos in Flows

We mentioned in Lecture 5, that flows on the plane cannot exhibit chaotic behaviour – in fact, the  $\omega$ –limit sets can only be equilibria, limit cycles or separatix cycles. But what can happen in three dimensions?

Consider the following system

$$\begin{aligned}\dot{x} &= \sigma(y - x) \\ \dot{y} &= rx - y - xz \\ \dot{z} &= xy - bz\end{aligned}$$

where  $\sigma, r, b$  are positive parameters –  $\sigma$  is called the *Prandtl number* and  $r$  is called the *Rayleigh number*.

For  $r < 1$  there is only one equilibrium of the system,

$$(x^*, y^*, z^*) = (0, 0, 0)$$

For  $r > 1$ , two more equilibria appear,

$$\begin{aligned}(x^*, y^*, z^*) &= (\sqrt{b(r-1)}, \sqrt{b(r-1)}, r-1) \\ (x^*, y^*, z^*) &= (-\sqrt{b(r-1)}, -\sqrt{b(r-1)}, r-1)\end{aligned}$$

In this case, at  $r = 1$  the zero equilibrium goes into a pitchfork bifurcation.

One of the most important properties of the Lorenz equations is *symmetry*: If  $(x(t), y(t), z(t))$  is a trajectory then so is  $(-x(t), -y(t), z(t))$  (you can see this if you substitute  $(x, y)$  with  $(-x, -y)$ : the equations stay the same).

Also, if we calculate  $\nabla \cdot \mathbf{f}$  we get

$$\nabla \cdot \mathbf{f} = \frac{\partial}{\partial x} (\sigma(y-x)) + \frac{\partial}{\partial y} (rx - y - xz) + \frac{\partial}{\partial z} (xy - bz) = -(1 + \sigma + b) < 0$$

i.e. the divergence of  $f$  is negative and so this system is volume contracting. This means that the Lorenz system cannot have repelling fixed points or closed orbits or even have quasi-periodic solutions as this would contradict the volume-contracting properties. This essentially means that fixed points must be either sinks or saddles and closed orbits must be stable or saddle-like.

Linearization of the system around the origin reveals that for  $r > 1$  it is a saddle point while for  $r < 1$  it is a sink. Actually, for  $r < 1$  the equilibrium is globally stable as revealed by the Lyapunov function

$$V(x, y, z) = \frac{1}{\sigma} x^2 + y^2 + z^2.$$

Hence, for  $r < 1$  there are no limit cycles or chaos.

The stability of the other two equilibria is a bit harder to analyze. If we assume that  $\sigma - b - 1 > 0$  then they are both linearly stable for

$$1 < r < \frac{\sigma(\sigma + b + 3)}{\sigma - b - 1} = r_H$$

At  $r_H$  the two equilibria undergo a Hopf bifurcation. For  $r < r_H$  the two equilibria are surrounded by an unstable limit cycle and so at  $r = r_H$  the equilibria undergo an *subcritical* Hopf bifurcation: for  $r > r_H$  the equilibrium changes into a saddle point and no attractors exist in the neighbourhood.

And here is the mystery: for  $r > r_H$  there is no stable equilibrium yet the system is volume contracting. There must be a distant attractor – but Lorenz showed that there is no stable limit cycles for  $r > r_H$  and trajectories cannot go to infinity. Therefore there must be a zero-volume object that attracts these trajectories.

Simulations of the system in this regime show that the motion is *aperiodic* and the phase-plane looks like a butterfly, called a *strange attractor* - an attractor which shows sensitivity to initial conditions. See Figure 59.

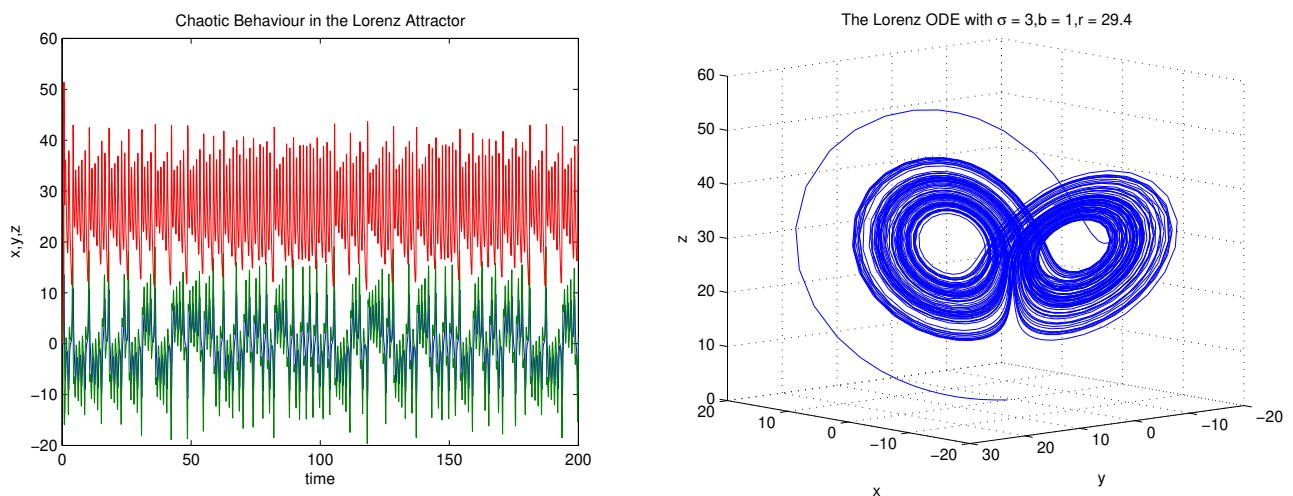

Figure 59: The Lorenz Attractor.

Just as in the case of maps, there is a certain sensitivity in the solution to initial conditions. A similar calculation to the case of maps, we can calculate the Lyapunov exponent indicating how small changes in initial conditions grow as the system evolves.

So what is Chaos? One requires three ingredients to say that a system is chaotic: aperiodic long-term behaviour; a deterministic system; and sensitivity to initial conditions. Chaos is *not* a 'cool' word for bistability! It should be used with caution.

### 8.3 Back to maps: Mandelbrot set

We have discussed the Mandelbrot set in Lecture 1. It involves the map

$$z_{k+1} = z_k^2 + c$$

where  $z, c \in \mathbb{C}$ . A point  $M = c$  is in the Mandelbrot set, if the trajectory  $z_j$  stays bounded, when the system is initialized from 0. The 2-dimensional set of parameters (the real and imaginary parts of  $c$ ), when plotted on an Argand diagram result in nice pictures. See Figure 60, and also try searching the internet for Mandelbrot Java applets.

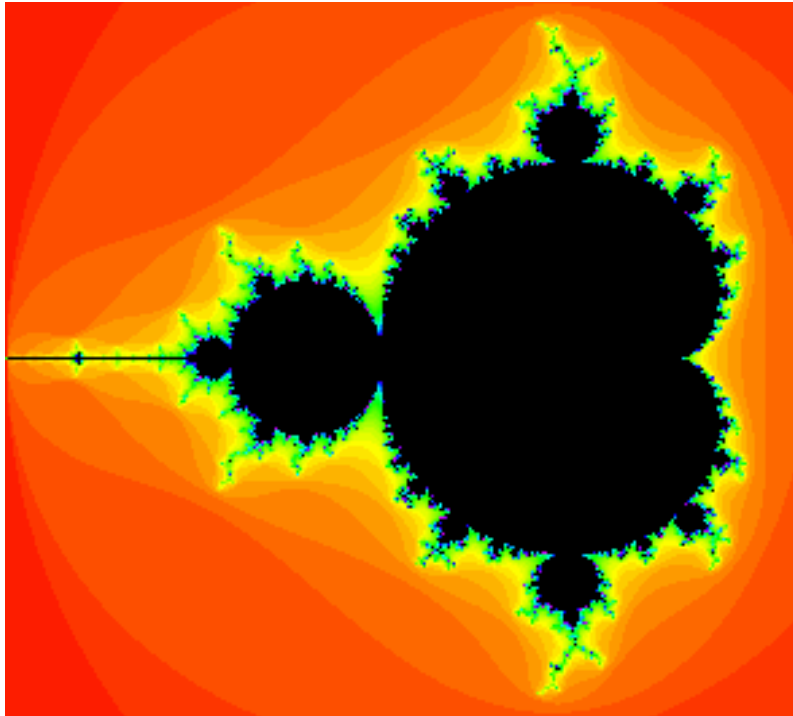

Figure 60: The Mandelbrot set.

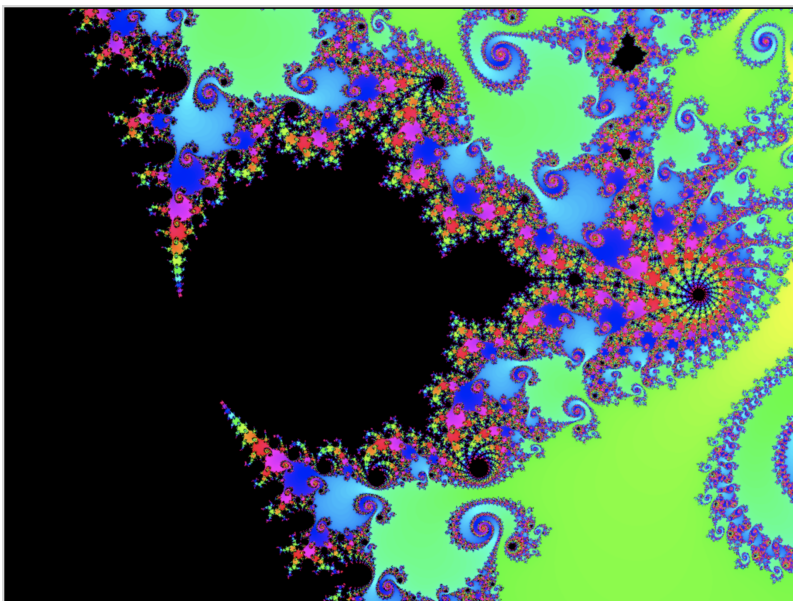

Figure 61: Another view of the Mandelbrot set (after scaling by  $10^3$ ).